

Film Capacitors

Series/Type: METALLIZED POLYPROPYLENE AC FILTER CAPACITOR-
Single phase
Series code: 296

296 METALLIZED POLYPROPYLENE AC FILTER CAPACITOR- Single phase

Part Number Description

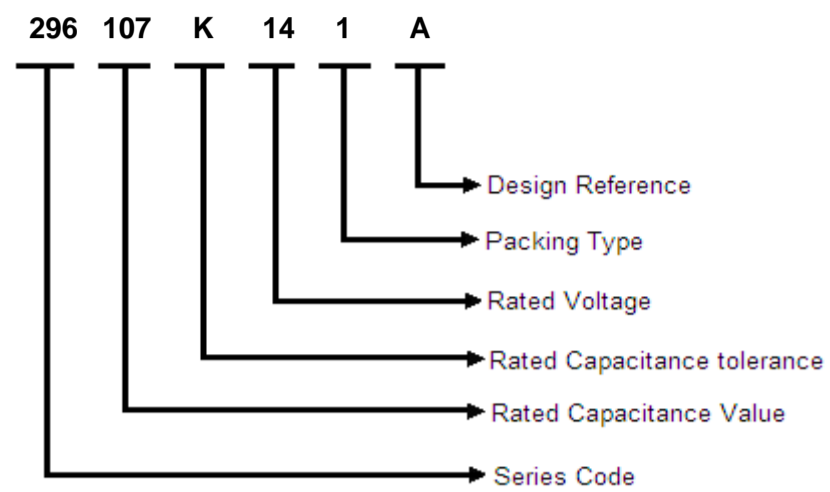

Rated Capacitance

Three-digit (224) indicate rated capacitance in Pico Farad (First two digits indicate value & third digit indicates number of zeroes to be suffixed to first two digits).

For example:

103	= 10 ×	10 ³	= 10000 pF	= 10 nF	=0.01 μF
104	= 10 ×	10 ⁴	= 100000 pF	= 100 nF	=0.1 μF
105	= 10 ×	10 ⁵	= 1000000 pF	= 1000 nF	=1 μF
106	= 10 ×	10 ⁶	= 10000000 pF	= 10000 nF	=10 μF

Capacitance Tolerance

F = ±1%, G = ±2%, H = ±2.5%, I = ±3.5%, J = ±5%, K = ±10%, L = ±15%, M = ±20%, N=±40%

Rated Voltage

One digit and one letter (2A) or two digits (05) indicate rated voltage

Rated Voltage Codification

For AC Rated Voltage(V _{RMS})													
01	02	03	04	05	06	07	08	09	10	11	12	13	14
190	250	275	305	310	440	500	600	700	63	230	330	400	450
15	16	17	18	19	20	21	22	23	24	25	26	27	
350	300	415	420	460	480	530	660	720	780	850	900	1000	

General Data

Typical Application

- UPS
- Wind Power
- Variable Frequency Drives
- Inverter

Construction

- Dielectric: Metallized Polypropylene Film
- Self-Healing Property
- Wound capacitor Technology
- Aluminum can
- Mounting and Grounding : stud on bottom of Can
- Non PCB, Soft Polyurethane resin

Features

- Compact size
- Low Loss
- Low ESR and ESL
- Low leakage current
- Safety device: Over Pressure disconnecter
- IP00 , IP20

Reference Standard

- IEC 61071, IEC 60831

Climatic Category

- 40/70/21

Terminals

- 294 series: M10 Stud

Technical Data

Max. Operating Temperature	+70° C
Min. Operating temperature	-40° C
Max. Hotspot temperature	+85° C
Rated Capacitance CR	5...600µF (Upon request)
Rated Voltage VR	Upto 1000V AC
Voltage proof(VT-T)	2.15xVRMS, 2s
Voltage proof(VT-C)	
Dissipation factor tan δ (100Hz)	≤0.001
Life Test	Acc. To IEC 61071-2017
Tolerance	J, ±5%
Degree of Protection	IP00, IP20
Max. permissible altitude	2000m MSL
Safety device	Over pressure disconnecter
Max. current(IRMS)	Refer to the chart
Self Inductance(ESL)	Refer to the chart
Service Life at VRMS @ 85° C Hotspot	100000Hrs*

*For conversion at different hotspot temperature and Voltage please see graph

only better

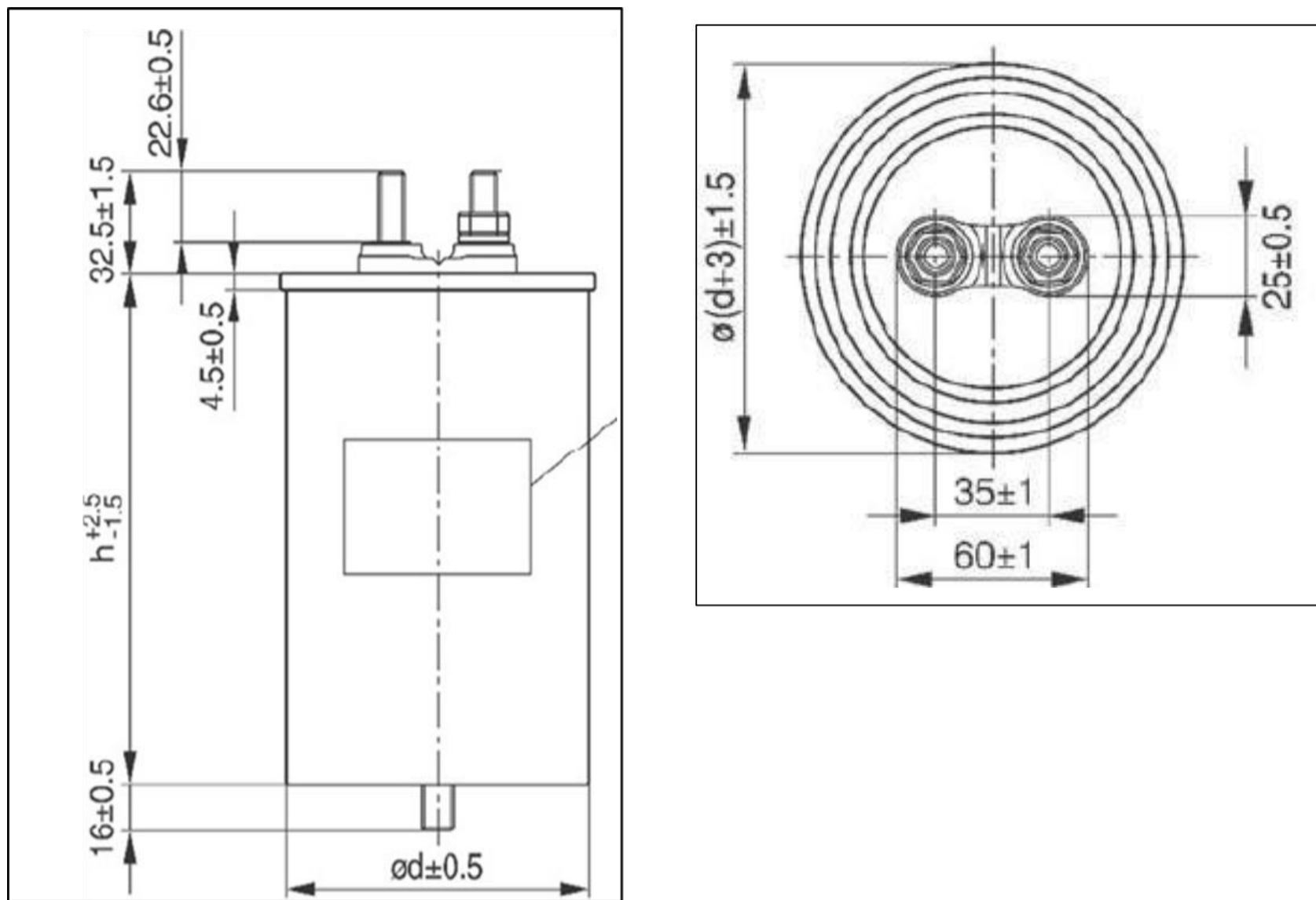

Series 294: Faston terminals with bottom stud for mounting

Installation Space requirements:

- A minimum distance of 20 mm between the capacitors is necessary to maintain cooling.
- Keep at least 20 mm space above the capacitor and do not attach any mounting components at the crimp or on top to allow proper lateral extension in order to ensure that the over pressure disconnecter can fully extend

VR/VRMS (V)	CR(μF)	I _{rms} (A)	I _{peak} (kA)	D mm	H mm	Item Code
350/250	150	41.5	1800	75	117	296 157 J 02 1 *
	200	45	2160	75	117	296 207 J 02 1 *
	250	45	2000	75	142	296 257 J 02 1 *
	300	60	3770	75	175	296 307 J 02 1 *
	330	60	3560	75	195	296 337 J 02 1 *
	400	60	3790	75	215	296 407 J 02 1 *
	500	60	5400	85	195	296 507 J 02 1 *
	600	60	4800	85	245	296 607 J 02 1 *
460/330	100	36	1440	75	117	296 107 J 12 1 *

only better

296 METALLIZED POLYPROPYLENE AC FILTER CAPACITOR- Single phase



	120	39	1720	75	117	296 127 J 12 1 *
	150	40	1600	75	142	296 157 J 12 1 *
	200	48	2130	85	142	296 207 J 12 1 *
	250	60	3600	85	195	296 257 J 12 1 *
	300	60	4320	85	195	296 307 J 12 1 *
	330	60	4160	85	215	296 337 J 12 1 *
	400	60	4260	85	245	296 407 J 12 1 *
	500	60	5330	96	245	296 507 J 12 1 *
590/420	60	32	1270	75	102	296 606 J 18 1 *
	70	33	1175	75	117	296 706 J 18 1 *
	80	35	1340	75	117	296 806 J 18 1 *
	100	35.5	1245	75	142	296 107 J 18 1 *
	120	51	2550	75	165	296 127 J 18 1 *
	150	59	3195	85	165	296 157 J 18 1 *
	200	60	3360	85	195	296 207 J 18 1 *
	250	60	3110	85	245	296 257 J 18 1 *
	300	60	3730	85	245	296 307 J 18 1 *
	350	60	4350	96	245	296 357 J 18 1 *
400	60	6720	116	195	296 407 J 18 1 *	
680/480	60	32	1150	75	117	296 606 J 20 1 *
	66	33	1260	75	117	296 666 J 20 1 *
	68	38	1655	85	102	296 686 J 20 1 *
	70	43	2050	75	145	296 706 J 20 1 *
	80	46	2360	75	145	296 806 J 20 1 *
	86	50	3400	85	120	296 866 J 20 1 *
	100	50	2430	75	165	296 107 J 20 1 *
	120	52	2300	75	195	296 127 J 20 1 *
	150	60	2880	85	195	296 157 J 20 1 *
	166	60	3200	85	195	296 167 J 20 1 *
	180	60	4400	96	165	296 187 J 20 1 *
	200	60	2840	85	245	296 207 J 20 1 *
	250	60	3550	96	245	296 257 J 20 1 *
	280	60	6250	116	175	296 287 J 20 1 *
	300	60	5840	116	195	296 307 J 20 1 *
350	60	5970	116	215	296 357 J 20 1 *	
750/530	30	25.5	938	75	102	296 306 J 21 1 *
	33	29	1100	85	92	296 336 J 21 1 *
	47	36	2210	75	120	296 476 J 21 1 *
	50	40	2280	75	120	296 506 J 21 1 *
	60	43	2740	85	120	296 606 J 21 1 *
	65	44	2960	85	120	296 656 J 21 1 *
	70	37	1325	85	127	296 706 J 21 1 *
	75	43	1880	96	107	296 756 J 21 1 *

only better

Expected FIT Rate at different hotspot and voltage

The Expected Failure rate are typical theoretical values derived from lifetime tests. The FIT (Failure in Time) of a component is defined as the number of expected failures in 10^9 hours of operation.



Service life expectancy at different hotspot temperature and voltage

Lifetime estimations are typical theoretical values derived from lifetime tests based on Deki's internal standards and IEC 61709

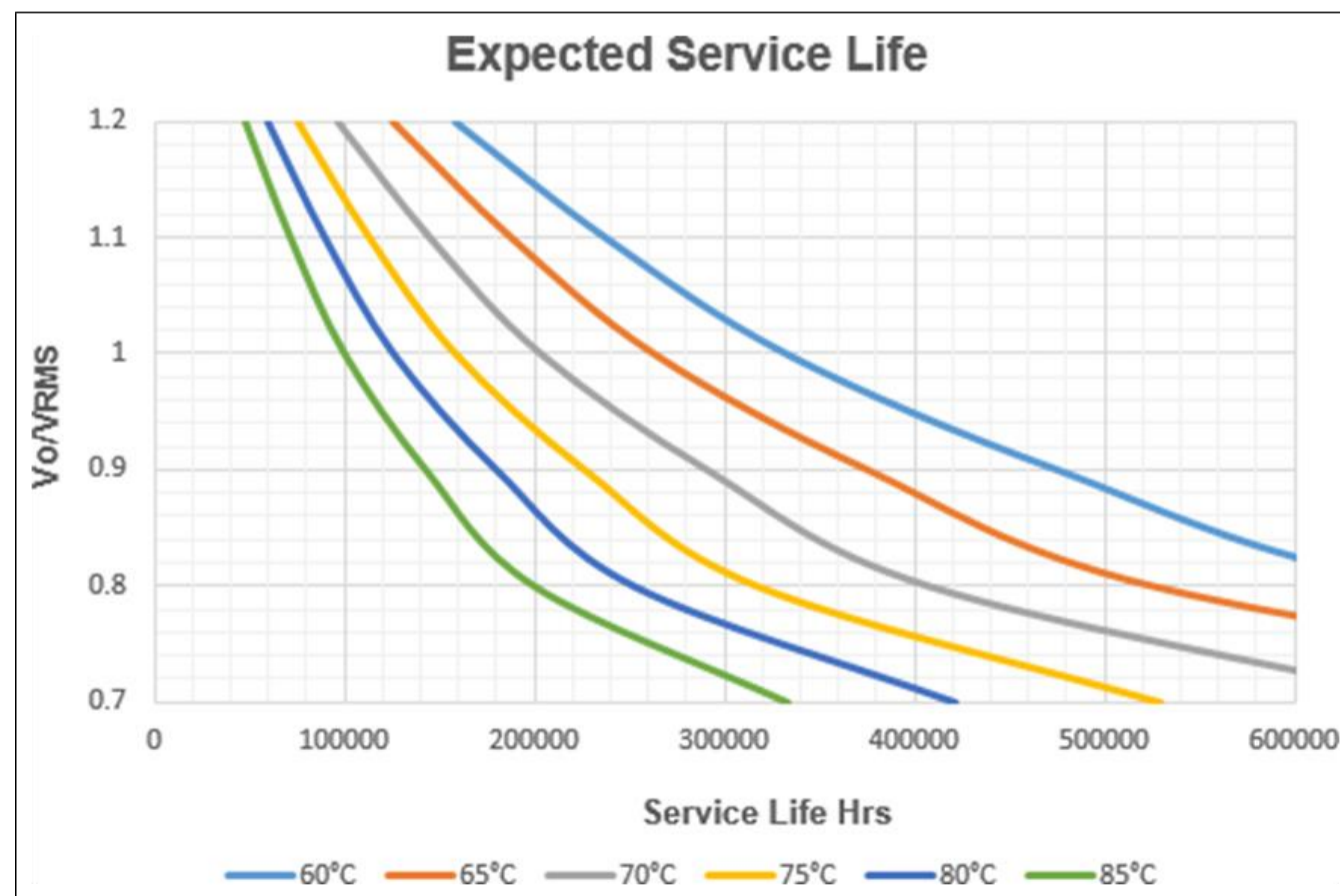

only better

Disclaimer

All our capacitors are designed, manufactured and tested to specifications. We strictly adhere to standards in procurement of materials, in the laid down manufacturing processes and consistently apply stringent process controls and testing parameters. This ensures that our capacitors always perform to the offered specifications. Appropriateness of use in a specific circuit and fitness to a particular application however needs to be verified and its reliability through expected lifetime is required to be validated by the customer. Deki's responsibility is limited to ensuring that the capacitor performs as claimed in the specification/ data sheets provided by Deki. Deki specifically disclaims any implied warranties of fitness for any particular purpose. Liability, in any case is limited to the price paid for the capacitors.