

# Film Capacitors

**Series/Type:** Metallized Polypropylene Dc Link  
**Series code:** 292

## Part Number Description

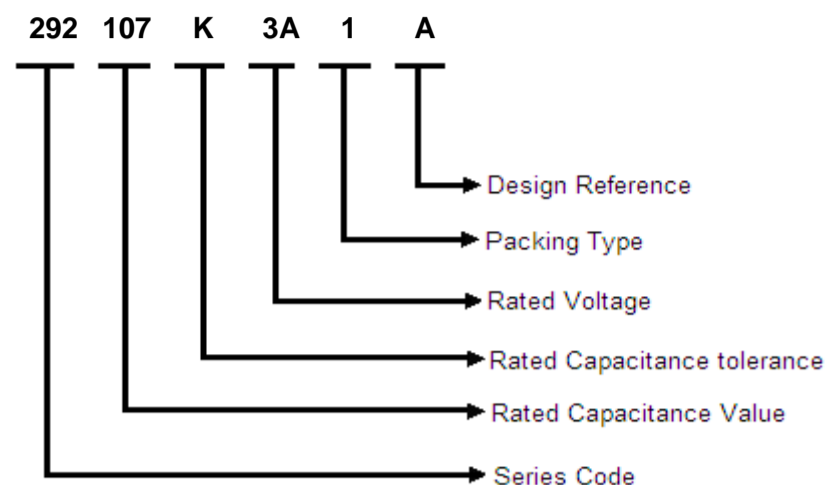

## Rated Capacitance

Three-digit (224) indicate rated capacitance in Pico Farad (First two digits indicate value & third digit indicates number of zeroes to be suffixed to first two digits).

For example:

103	= 10 ×	10 <sup>3</sup>	= 10000 pF	= 10 nF	=0.01 μF
104	= 10 ×	10 <sup>4</sup>	= 100000 pF	= 100 nF	=0.1 μF
105	= 10 ×	10 <sup>5</sup>	= 1000000 pF	= 1000 nF	=1 μF
106	= 10 ×	10 <sup>6</sup>	= 10000000 pF	= 10000 nF	=10 μF

## Capacitance Tolerance

F = ±1%, G = ±2%, H = ±2.5%, I = ±3.5%, J = ±5%, K = ±10%, L = ±15%, M = ±20%, N=±40%

## Rated Voltage

One digit and one letter (2A) or two digits (05) indicate rated voltage

## Rated Voltage Codification

For DC Rated Voltage													
A		B		C		D		E		F		G	
1A	10	1B	12.5	1C	16	1D	20	1E	25	1F	30	1G	40
2A	100	2B	125	2C	160	2D	200	2E	250	2F	300	2G	400
3A	1000	3B	1250	3C	1600	3D	2000	3E	2500	3F	3000	3G	4000
H		I		J		K		L		M		N	
1H	50	1I	45	1J	63	1K	70	1L	80	1M	85	1N	90
2H	500	2I	450	2J	630	2K	700	2L	800	2M	850	2N	900
3H	5000	3I	4500	3J	6300	3K	7000	3L	8000	3M	8500	3N	9000
O		P		Q		R		S		U		V	
1O	110	1P	120	1Q	57.5	1R	15	1S	17	1U	130	1V	60
2O	1100	2P	1200	2Q	575	2R	150	2S	170	2U	1300	2V	600
3O	11000	3P	12000	3Q	5750	3R	1500	3S	1700	3U	13000	3V	6000

## General Data

### Typical Application

- UPS
- Wind Power
- Variable Frequency Drives
- Solar inverter

### Construction

- Dielectric: Metallized Polypropylene Film
- Self-Healing Property
- Wound capacitor Technology
- Plastic Case (UL 94 V-0)
- Hard Polyurethane resin

### Features

- Compact size
- Low Loss
- Low ESR and ESL
- Low leakage current
- Lateral mounting Brackets

### Climatic Category

- 40/85/56

### Terminals

- Female Extruded Stud :M6 or M8

## Technical Data

Max. Operating Temperature	+85° C
Min. Operating temperature	-40° C
Rated Capacitance CR	20...270μF (Upon request)
Rated Voltage VR	Upto 2000V DC
Voltage proof(VT-T)	1.5xVRdc, 10s
Dissipation factor tan δ (1KHz)	≤0.002
Life Test	Acc. To IEC 61071-2017
Tolerance	K, ±10%
Degree of Protection	IP00(Indoor Mounting)
Max. permissible altitude	2000m MSL
Safety device	No internal protection
Max. current(IRMS)	Refer to the chart
Self Inductance(ESL)	Refer to the chart
Failure rate at VR DC @ 70° C Hotspot	100 FIT*
Service Life at VR DC @ 70° C Hotspot	100000Hrs*

\*For conversion at different hotspot temperature and Voltage please see graph

only better

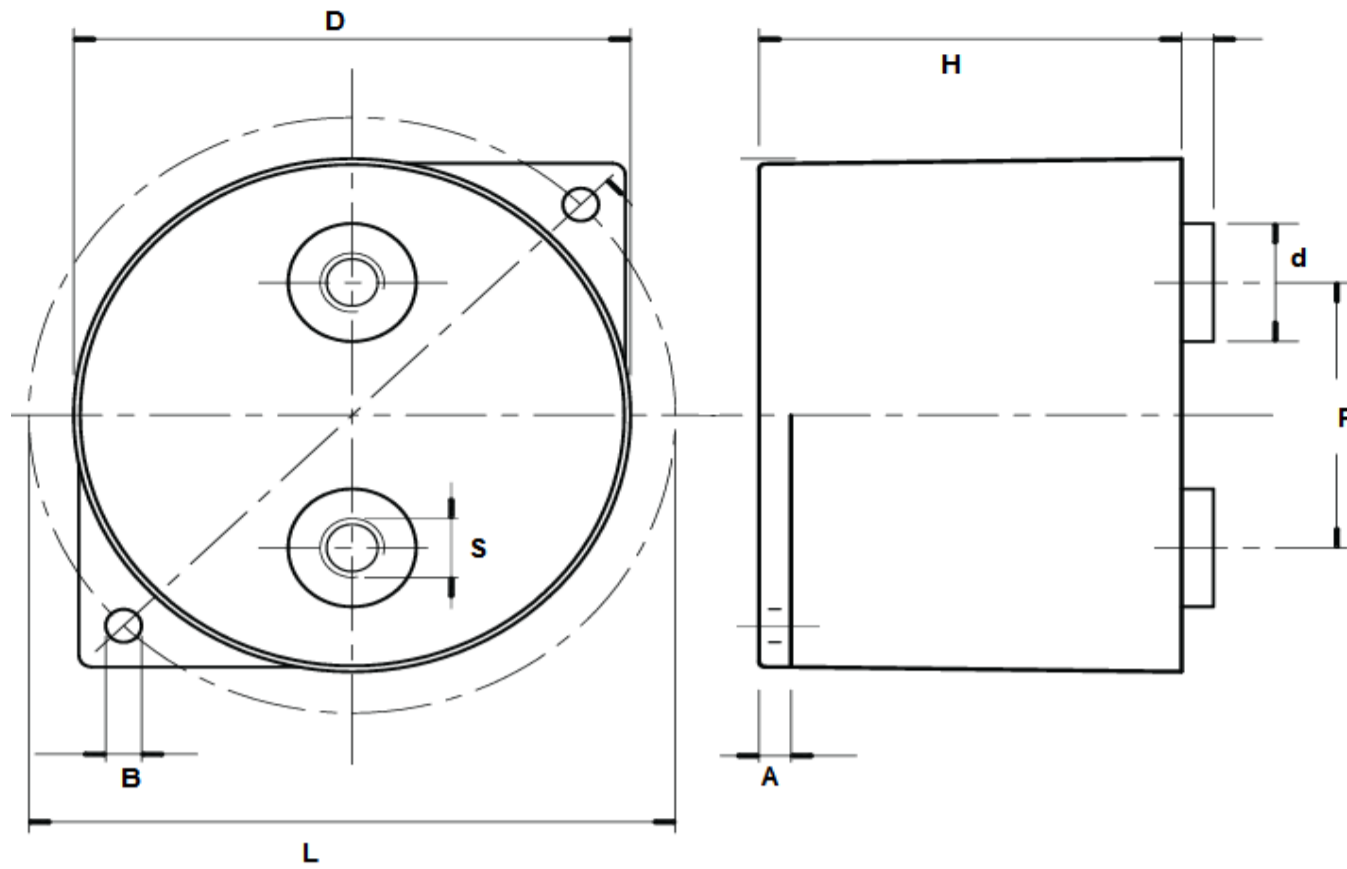

D(±2.0) mm	H(±2.0) mm	P(±1.0) mm	d(±1.0) mm	S	L(±0.5) mm	B(±0.5) mm
85	51	45	18	M6 or M8	101	5.5
85	65	45	18	M6 or M8	101	5.5

VR (VDC)	CR(μF)	*I <sub>rms</sub> (A)	I <sub>peak</sub> (kA)	I <sub>s</sub> (kA)	**ESR(mΩ)	***ESL(nH)	Item Code
600	180	55	1.4	4.2	0.9	13	292 187 K 2V 1*
	270	60	1.4	4.2	1.2	15	292 277 K 2V 1*
700	140	55	1.5	4.6	0.9	13	292 147 K 2K 1*
	210	60	1.5	4.6	1.2	15	292 217 K 2K 1*
800	110	55	2.1	6.2	1.0	13	292 117 K 2L 1*
	160	60	2.0	5.9	1.3	15	292 167 K 2L 1*
900	90	55	2.5	7.5	1.0	13	292 906 K 2N 1*
	130	60	2.4	7.2	1.3	15	292 137 K 2N 1*
1000	110	50	2.1	6.2	1.2	13	292 117 K 3A 1*
	160	55	2.0	5.9	1.4	15	292 167 K 3A 1*
1100	72	50	2.2	6.6	1.1	13	292 726 K 2O 1*
	110	55	2.2	6.7	1.4	15	292 117 K 2O 1*
1200	55	50	2.0	6.1	1.3	13	292 556 K 2P 1*
	85	55	2.0	6.0	1.6	15	292 856 K 2P 1*
1300	48	50	1.9	5.8	1.4	13	292 486 K 2U 1*
	75	55	1.9	5.8	1.7	15	292 756 K 2U 1*
1500	36	45	1.7	5.0	1.6	13	292 366 K 3R 1*
	56	50	1.7	5.0	1.9	15	292 566 K 3R 1*
1600	30	45	1.5	4.4	1.7	13	292 306 K 3C 1*
	48	50	1.5	4.5	2.3	15	292 486 K 3C 1*
2000	20	40	1.2	3.7	1.8	13	292 206 K 3D 1*
	30	45	1.2	3.5	2.5	15	292 306 K 3D 1*

\*I<sub>rms</sub> at 10 KHz.

\*\*Equivalent series resistance ESR at 10 KHz.

\*\*\*Equivalent series inductance ESL at resonance condition.

### Expected FIT Rate at different hotspot and voltage

The Expected Failure rate are typical theoretical values derived from lifetime tests. The FIT (Failure in Time) of a component is defined as the number of expected failures in  $10^9$  hours of operation.

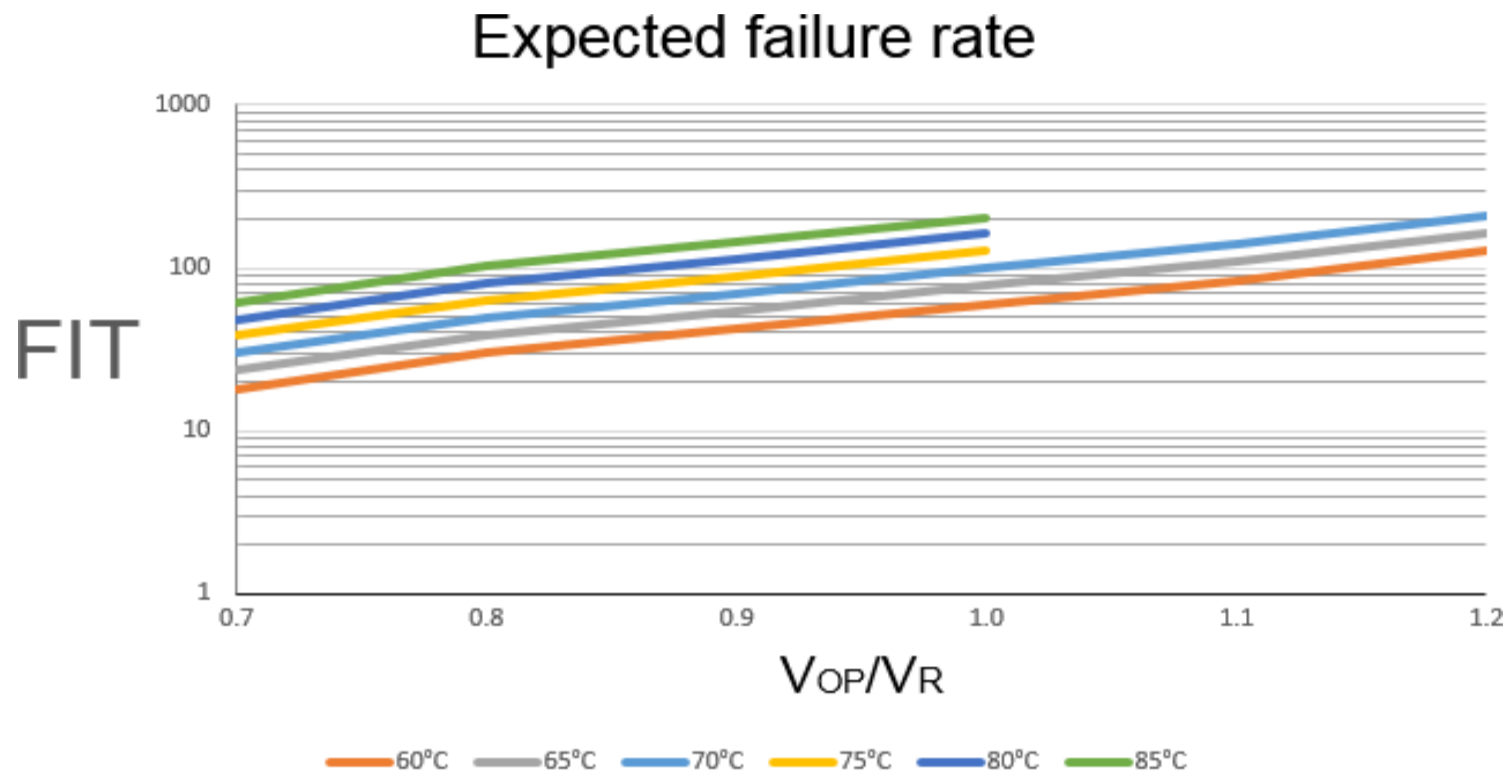

### Service life expectancy at different hotspot temperature and voltage

Lifetime estimations are typical theoretical values derived from lifetime tests based on Deki's internal standards and IEC 61709

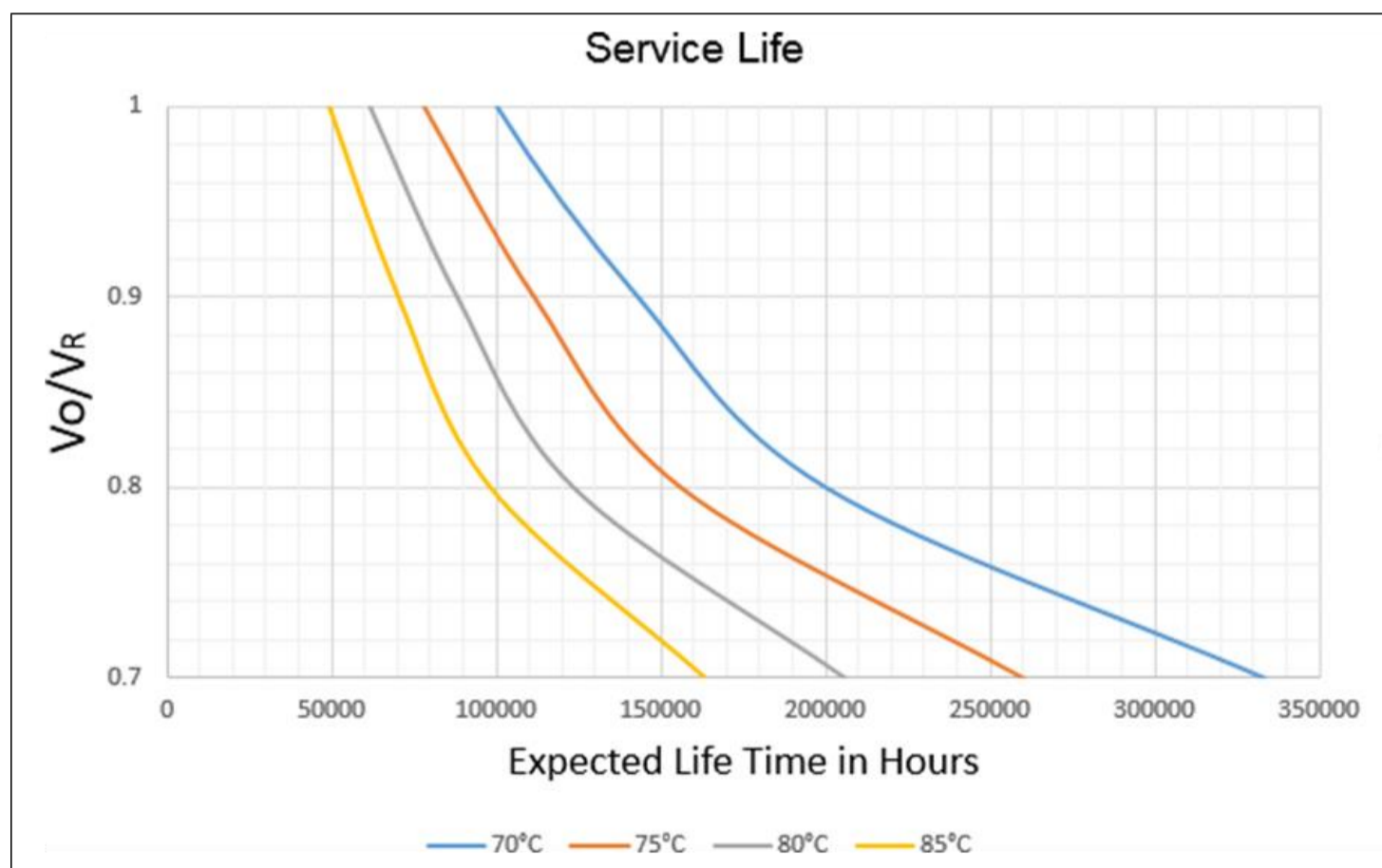

---

## Disclaimer

All our capacitors are designed, manufactured and tested to specifications. We strictly adhere to standards in procurement of materials, in the laid down manufacturing processes and consistently apply stringent process controls and testing parameters. This ensures that our capacitors always perform to the offered specifications. Appropriateness of use in a specific circuit and fitness to a particular application however needs to be verified and its reliability through expected lifetime is required to be validated by the customer. Deki's responsibility is limited to ensuring that the capacitor performs as claimed in the specification/ data sheets provided by Deki. Deki specifically disclaims any implied warranties of fitness for any particular purpose. Liability, in any case is limited to the price paid for the capacitors.