

Film Capacitors

Series/Type: Metallized Polypropylene IGBT Snubber Capacitors (MPP-MPP TYPE)

Series code: 150

150 Metallized Polypropylene IGBT Snubber Capacitors (MPP-MPP TYPE)

Part Number Description

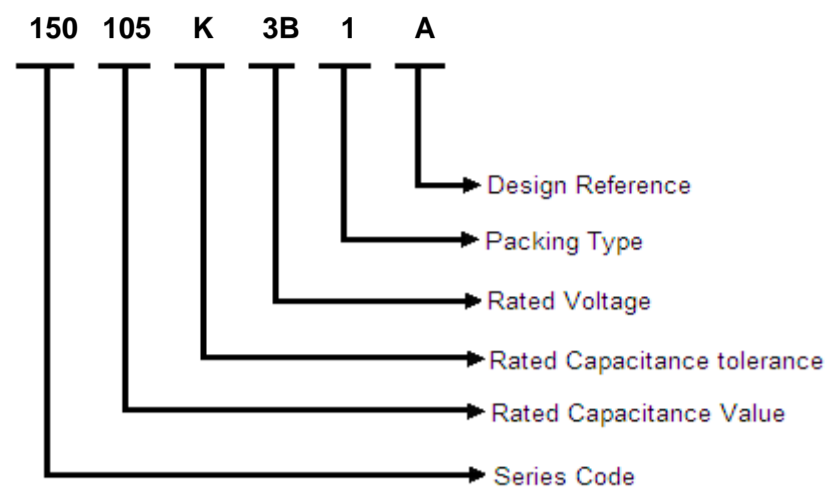

Rated Capacitance

Three-digit (105) indicate rated capacitance in Pico Farad (First two digits indicate value & third digit indicates number of zeroes to be suffixed to first two digits).

For example:

103	= 10 ×	10 ³	=	10000 pF	=	10 nF	=	0.01 μF
104	= 10 ×	10 ⁴	=	100000 pF	=	100 nF	=	0.1 μF
105	= 10 ×	10 ⁵	=	1000000 pF	=	1000 nF	=	1 μF
106	= 10 ×	10 ⁶	=	10000000 pF	=	10000 nF	=	10 μF

Capacitance Tolerance

F = ±1%, G = ±2%, H = 2.5%, I = ±3.5%, J = ±5%, K = ±10%, L = ±15%, M = ±20%, N=±30%

Rated Voltage

One digit and one letter (2J) or two digits indicate rated voltage.

Rated Voltage Codification

For DC Rated Voltage													
A		B		C		D		E		F		G	
1A	10	1B	12.5	1C	16	1D	20	1E	25	1F	30	1G	40
2A	100	2B	125	2C	160	2D	200	2E	250	2F	300	2G	400
3A	1000	3B	1250	3C	1600	3D	2000	3E	2500	3F	3000	3G	4000
H		I		J		K		L		M		N	
1H	50	1I	45	1J	63	1K	70	1L	80	1M	85	1N	90
2H	500	2I	450	2J	630	2K	700	2L	800	2M	850	2N	900
3H	5000	3I	4500	3J	6300	3K	7000	3L	8000	3M	8500	3N	9000
O		P		Q		R		S		U		V	
1O	110	1P	120	1Q	57.5	1R	15	1S	17	1U	130	1V	60
2O	1100	2P	1200	2Q	575	2R	150	2S	170	2U	1300	2V	600
3O	11000	3P	12000	3Q	5750	3R	1500	3S	1700	3U	13000	3V	6000
For AC Rated Voltage													
01	02	03	04	05	06	07	08	09	10	11	12	13	14
190 VAC	250 VAC	275 VAC	305 VAC	310 VAC	440 VAC	500 VAC	600 VAC	700 VAC	63 VAC	230 VAC	330 VAC	400 VAC	450 VAC

150 Metallized Polypropylene IGBT Snubber Capacitors (MPP-MPP TYPE)

*Packing Type details:

- 1: Bulk packing (original pitch)
- 2: Bulk packing (after forming & cutting)
- 3: Ammo packing (after forming & taping)
- 4: Bulk packing (after forming in original pitch without cut)
- 5: Bulk packing (after formed & without cut)
- 6: Ammo packing (Straight lead)
- 7: Bulk packing (Straight lead cut)
- 8: Reel packing (Straight lead)

Reference Data

Capacitance	1.5 μ F to 10 μ F
Capacitance tolerance	\pm 5%, \pm 10%
Rated AC voltage Range	700Vdc to 3000Vdc
Climatic testing class according to IEC 60068-1	40/85/56
Rated temperature	85°C
Reference standards	IEC-61071
Dielectric	Polypropylene
Electrodes	Metallized
Construction	series
Encapsulation	Incased in flame retardant box
Leads	Tin Plated copper lugs
Marking on capacitor body	DEKI / IGBT-SNUBBER/MPP-MPP/0.47 μ F/K/1000V/LOT NO-A
Compatibility to RoHS	

150 Metallized Polypropylene IGBT Snubber Capacitors (MPP-MPP TYPE)



Dimensions Description

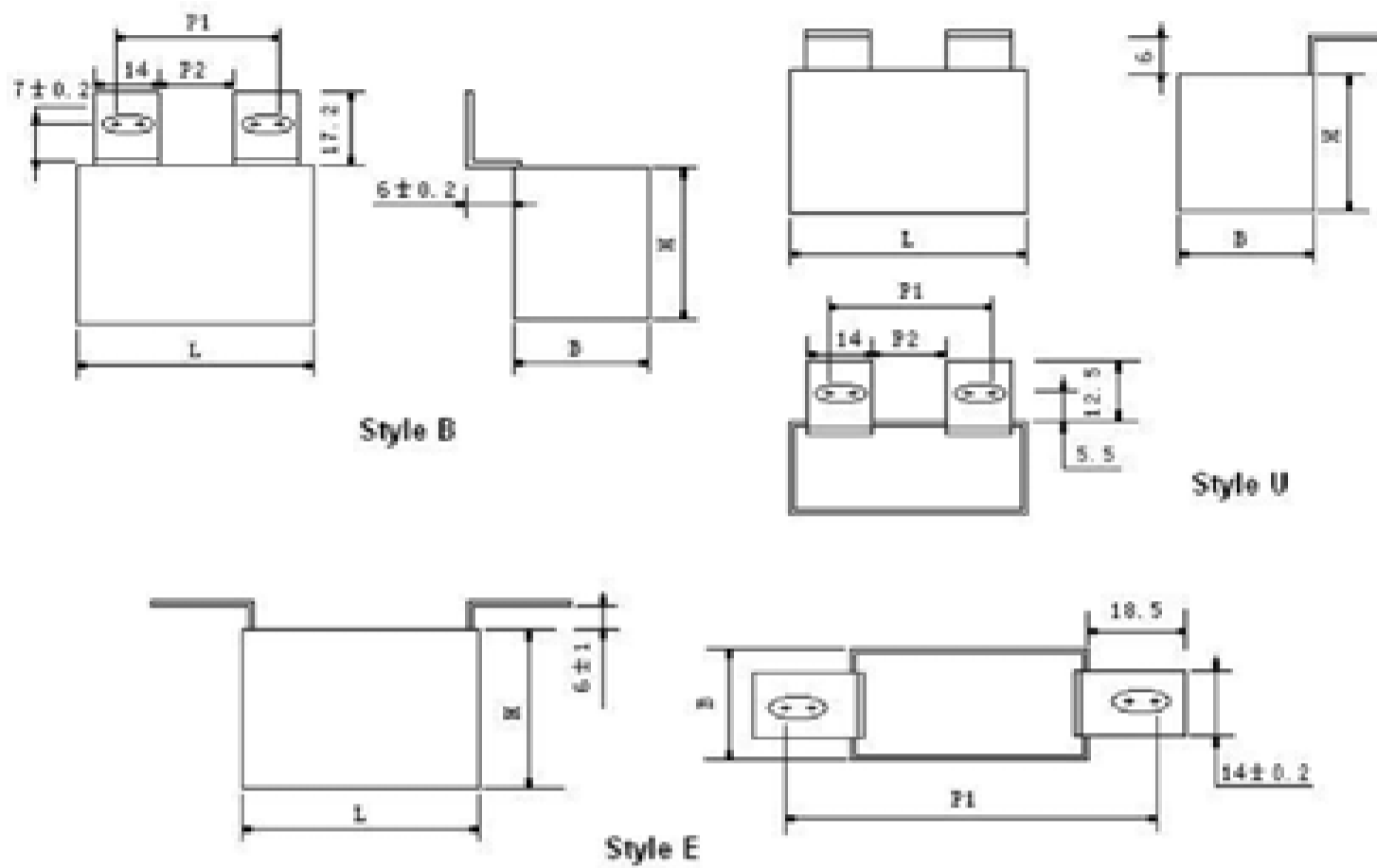

Rated Cap. (μF)	W (±0.5)	Dimensions (mm) H (±0.5)	L (±0.5)	dv/dt (V/μs)	Ipeak (A)	Irms (max) (A)	ESR (mΩ)	Ordering Code
Ur 700VDC, Urms 380VAC, Upk 1000VDC								
1.5	24.5	27.5	43.0	132	198	15	3.6	150 155 +2K ^A
2.0	33.5	36.0	43.0	132	264	16	3.1	150 205 +2K ^A
3.0	33.5	36.0	43.0	132	396	20	2.6	150 305 +2K ^A
3.3	33.5	36.0	43.0	132	436	21	2.5	150 335 +2K ^A
4.0	33.5	36.0	43.0	132	528	23	2.2	150 405 +2K ^A
4.7	34.0	46.0	43.0	132	620	26	1.9	150 475 +2K ^A
5.0	34.0	46.0	43.0	132	660	26	1.9	150 505 +2K ^A
5.6	34.0	46.0	43.0	132	739	27	1.8	150 565 +2K ^A
6.8	30.0	50.0	57.5	90	612	27	2.3	150 685 +2K ^A
8.2	35.0	50.0	57.5	90	738	32	2.1	150 825 +2K ^A
10.0	35.0	50.0	57.5	90	900	32	1.9	150 106 +2K ^A
Ur 850VDC, Urms 450VAC, Upk 1200VDC								
1.2	24.5	27.5	43.0	200	240	15	3.3	150 125 +2M ^A
2.2	24.5	27.5	43.0	200	440	23	2.3	150 225 +2M ^A
2.5	33.5	36.0	43.0	200	500	24	2.1	150 255 +2M ^A
2.7	33.5	36.0	43.0	200	540	24	2.0	150 275 +2M ^A
3.0	33.5	36.0	43.0	200	600	26	1.9	150 305 +2M ^A
3.3	34.0	46.0	43.0	200	660	27	1.8	150 335 +2M ^A
4.0	34.0	46.0	43.0	200	800	28	1.7	150 405 +2M ^A
4.7	30.0	46.0	57.5	110	517	27	2.2	150 475 +2M ^A
5.0	30.0	46.0	57.5	110	550	28	2.2	150 505 +2M ^A
5.6	35.0	50.0	57.5	110	616	32	1.9	150 565 +2M ^A
6.8	35.0	50.0	57.5	110	748	32	1.8	150 685 +2M ^A
Ur 1000VDC, Urms 480VAC, Upk 1400VDC								
1.0	24.5	27.5	43.0	225	225	15	3.3	150 105 +3A ^A
2.0	33.5	36.0	43.0	225	450	23	2.1	150 205 +3A ^A
2.5	34.0	46.0	43.0	225	563	27	1.8	150 255 +3A ^A
3.3	30.0	46.0	57.5	130	429	26	2.4	150 335 +3A ^A
4.7	35.0	50.0	57.5	130	611	32	1.9	150 475 +3A ^A
Ur 1200VDC, Urms 500VAC, Upk 1600VDC								
0.68	24.5	27.5	43.0	225	153	13	4.1	150 684 +2P ^A
1.5	33.5	36.0	43.0	225	338	21	2.6	150 155 +2P ^A
2.0	34.0	46.0	43.0	225	450	26	2.0	150 205 +2P ^A

only better

150 Metallized Polypropylene IGBT Snubber Capacitors (MPP-MPP TYPE)



2.2	34.0	46.0	43.0	225	195	27	1.9	150 225 +2P ^A
2.5	30.0	46.0	57.5	150	375	26	2.4	150 255 +2P ^A
3.0	35.0	50.0	57.5	150	450	30	2.1	150 305 +2P ^A
3.3	35.0	50.0	57.5	150	495	31	2.0	150 335 +2P ^A
Ur 1500VDC, Urms 575VAC, Upk 2000VDC								
0.33	24.5	27.5	43.0	225	74	12	5.6	150 334 +3R ^A
0.47	24.5	27.5	43.0	225	106	13	4.5	150 474 +3R ^A
0.68	33.5	36.0	43.0	225	153	18	3.8	150 684 +3R ^A
1.0	33.5	36.0	43.0	225	225	21	2.6	150 105 +3R ^A
1.2	34.0	46.0	43.0	225	180	25	2.1	150 125 +3R ^A
1.5	30.0	46.0	57.0	150	225	23	3.1	150 155 +3R ^A
2.0	35.0	50.0	57.5	150	300	27	2.6	150 205 +3R ^A
2.2	35.0	50.0	57.5	150	385	28	2.5	150 225 +3R ^A
Ur 1600VDC, Urms 575VAC, Upk 2200VDC								
1.0	33.5±1.0	35.5±1.0	42.0±1	-	-	-	4.5	150 105 K 3C 1 A

Rated Cap. (µF)	W (±0.5)	H (±0.5)	L (±0.5)	dv/dt (V/µs)	Ipeak (A)	Irms (max) (A)	ESR (mΩ)	Ordering Code
Ur 700VDC, Urms 380VAC, Upk 1000VDC								
1.5	24.5	27.5	43.0	132	198	15	3.6	150 155 +2K ^A
2.0	33.5	36.0	43.0	132	264	16	3.1	150 205 +2K ^A
3.0	33.5	36.0	43.0	132	396	20	2.6	150 305 +2K ^A
3.3	33.5	36.0	43.0	132	436	21	2.5	150 335 +2K ^A
4.0	33.5	36.0	43.0	132	528	23	2.2	150 405 +2K ^A
4.7	34.0	46.0	43.0	132	620	26	1.9	150 475 +2K ^A
5.0	34.0	46.0	43.0	132	660	26	1.9	150 505 +2K ^A
5.6	34.0	46.0	43.0	132	739	27	1.8	150 565 +2K ^A
6.8	30.0	50.0	57.5	90	612	27	2.3	150 685 +2K ^A
8.2	35.0	50.0	57.5	90	738	32	2.1	150 825 +2K ^A
10.0	35.0	50.0	57.5	90	900	32	1.9	150 106 +2K ^A
Ur 850VDC, Urms 450VAC, Upk 1200VDC								
1.2	24.5	27.5	43.0	200	240	15	3.3	150 125 +2M ^A
2.2	24.5	27.5	43.0	200	440	23	2.3	150 225 +2M ^A
2.5	33.5	36.0	43.0	200	500	24	2.1	150 255 +2M ^A
2.7	33.5	36.0	43.0	200	540	24	2.0	150 275 +2M ^A
3.0	33.5	36.0	43.0	200	600	26	1.9	150 305 +2M ^A
3.3	34.0	46.0	43.0	200	660	27	1.8	150 335 +2M ^A
4.0	34.0	46.0	43.0	200	800	28	1.7	150 405 +2M ^A
4.7	30.0	46.0	57.5	110	517	27	2.2	150 475 +2M ^A
5.0	30.0	46.0	57.5	110	550	28	2.2	150 505 +2M ^A
5.6	35.0	50.0	57.5	110	616	32	1.9	150 565 +2M ^A
6.8	35.0	50.0	57.5	110	748	32	1.8	150 685 +2M ^A
Ur 1000VDC, Urms 480VAC, Upk 1400VDC								
1.0	24.5	27.5	43.0	225	225	15	3.3	150 105 +3A ^A
2.0	33.5	36.0	43.0	225	450	23	2.1	150 205 +3A ^A
2.5	34.0	46.0	43.0	225	563	27	1.8	150 255 +3A ^A
3.3	30.0	46.0	57.5	130	429	26	2.4	150 335 +3A ^A
4.7	35.0	50.0	57.5	130	611	32	1.9	150 475 +3A ^A
Ur 1200VDC, Urms 500VAC, Upk 1600VDC								
0.68	24.5	27.5	43.0	225	153	13	4.1	150 684 +2P ^A
1.5	33.5	36.0	43.0	225	338	21	2.6	150 155 +2P ^A
2.0	34.0	46.0	43.0	225	450	26	2.0	150 205 +2P ^A
2.2	34.0	46.0	43.0	225	195	27	1.9	150 225 +2P ^A
2.5	30.0	46.0	57.5	150	375	26	2.4	150 255 +2P ^A
3.0	35.0	50.0	57.5	150	450	30	2.1	150 305 +2P ^A
3.3	35.0	50.0	57.5	150	495	31	2.0	150 335 +2P ^A

only better

150 Metallized Polypropylene IGBT Snubber Capacitors (MPP-MPP TYPE)



Ur 1500VDC, Urms 575VAC, Upk 2000VDC								
0.33	24.5	27.5	43.0	225	74	12	5.6	150 334 +3R ^A
0.47	24.5	27.5	43.0	225	106	13	4.5	150 474 +3R ^A
0.68	33.5	36.0	43.0	225	153	18	3.8	150 684 +3R ^A
1.0	33.5	36.0	43.0	225	225	21	2.6	150 105 +3R ^A
1.2	34.0	46.0	43.0	225	180	25	2.1	150 125 +3R ^A
1.5	30.0	46.0	57.0	150	225	23	3.1	150 155 +3R ^A
2.0	35.0	50.0	57.5	150	300	27	2.6	150 205 +3R ^A
2.2	35.0	50.0	57.5	150	385	28	2.5	150 225 +3R ^A
Ur 1600VDC, Urms 575VAC, Upk 2200VDC								
1.0	33.5±1.0	35.5±1.0	42.0±1	-	-	-	4.5	150 105 K 3C 1 A

Style	Style B				Style U				Style E
Length (mm)	P2	P1	P2	P1	P2	P1	P2	P1	P1
43.0	11	23-28	8	20-25	11	23-28	8	20-25	51-64
57.5	11	23-28	24	37-42	11	23-28	24	37-42	66-79

Specific Data

Description	Value
Maximum tangent of loss angle	At 1 kHz
	0.0006
Voltage proof test between leads	1.65 X Rated voltage for 2 Sec.
Insulation Resistance (R _{IS}) (or) time constant T= C _R × R _{IS} at 25° C, relative humidity ≤70%	C _R ≤0.33μF
	CR>0.33 μf
	≥100000MΩ
	≥30000 s

Temperature Derating Graph

For temperature between 85°C and 100°C a derating factor of 1.25% per °C on the rated voltage VR has to be applied

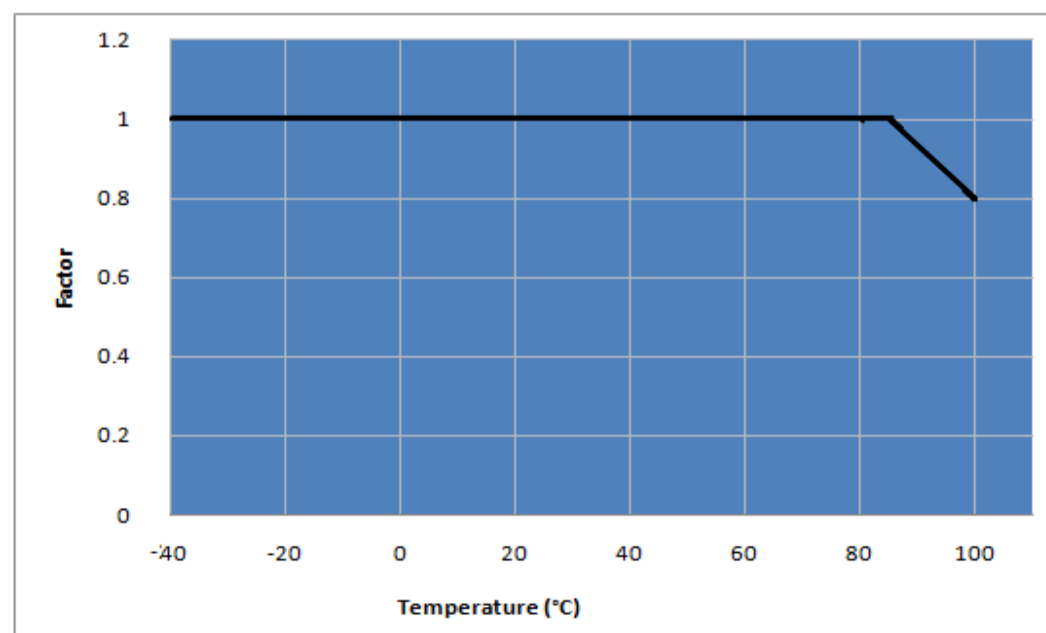

only better

Power Dissipation and Maximum Component Temperature Rise

After applying the A.C voltage to the capacitor with certain frequency, we can measure the hot spot temperature of the capacitor. From that we can calculate ΔT .

ΔT = hot spot temperature – ambient temperature

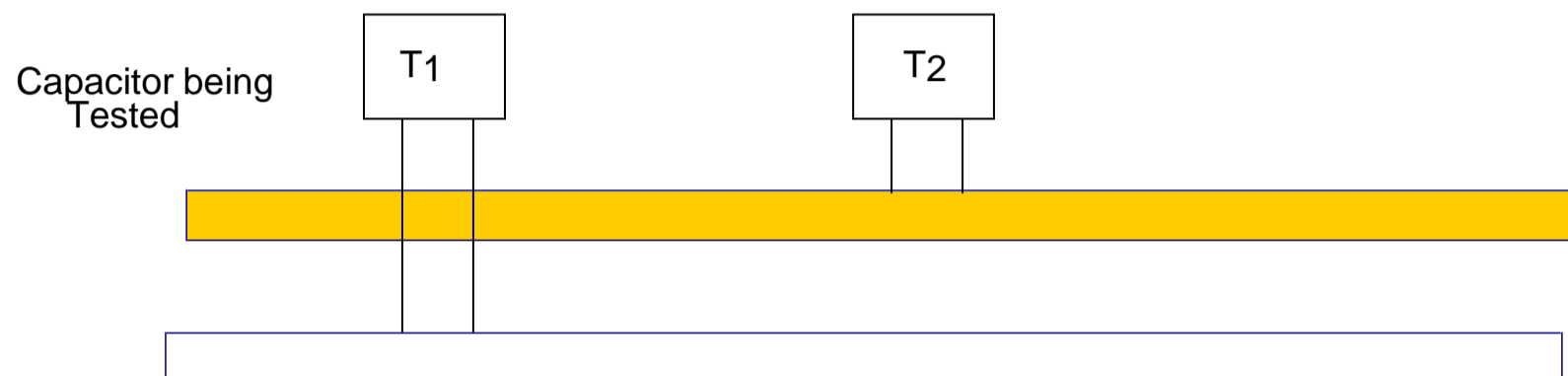

T1 is the capacitor under test (Connected in the circuit)

T2 is capacitor which has no connection

Distance between T1 and T2 should be about 50mm and 100mm from other components. To avoid radiation or convection, the capacitor should be tested in a wind-free box. The capacitor under test is separated by polystyrene

$$\Delta T_{\max} = T1 - T2$$

at one frequency level the ΔT_{\max} reach 10°C. That is the frequency which we have to start frequency derating.

Storage Conditions

Avoid storing the capacitors in places where the environmental conditions differ from the following:

Storage time: ≤ 24 months from the date marked on the label glued to the package.

- Temperature: -40 to 80°C
- Humidity:

- Average per year: $\leq 70\%$
- For 30 full days randomly distributed throughout the year: $\leq 85\%$
- Dew: absent

After a longer period of storage or use, the tolerance can increase; but, according to standard specification, it may never exceed twice the value measured at the time of delivery.

Disclaimer

All our capacitors are designed, manufactured and tested to specifications. We strictly adhere to standards in procurement of materials, in the laid down manufacturing processes and consistently apply stringent process controls and testing parameters. This ensures that our capacitors always perform to the offered specifications. Appropriateness of use in a specific circuit and fitness to a particular application however needs to be verified and its reliability through expected lifetime is required to be validated by the customer. Deki's responsibility is limited to ensuring that the capacitor performs as claimed in the specification/ data sheets provided by Deki. Deki specifically disclaims any implied warranties of fitness for any particular purpose. Liability, in any case is limited to the price paid for the capacitors.

only better