

Film Capacitors

Series/Type: Metallized Polyester Film Capacitors
MPET (Box Type) 10-27.5mm Pitch
Series code: 06

06 Metallized Polyester Film Capacitors MPET – (Box Type) 10-27.5mm Pitch

Part Number Description

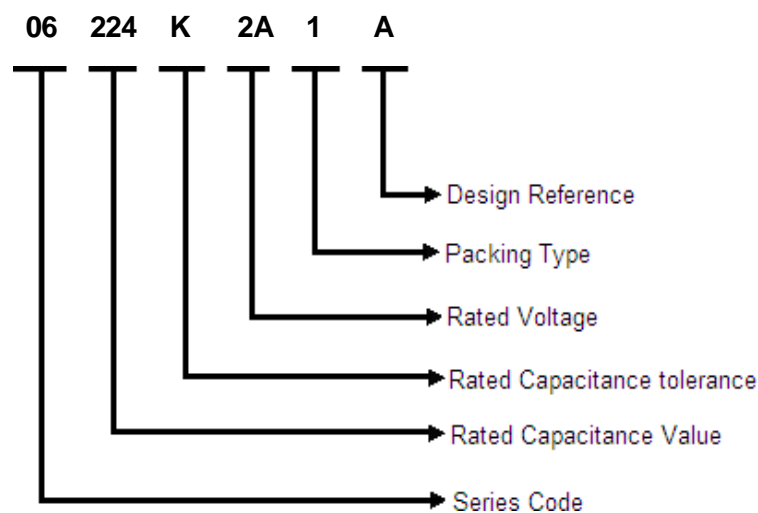

Rated Capacitance

Three-digit (224) indicate rated capacitance in Pico Farad (First two digits indicate value & third digit indicates number of zeroes to be suffixed to first two digits).

For example:

103	= 10 ×	10 ³	= 10000 pF	= 10 nF	=0.01 μF
104	= 10 ×	10 ⁴	= 100000 pF	= 100 nF	=0.1 μF
105	= 10 ×	10 ⁵	= 1000000 pF	= 1000 nF	=1 μF
106	= 10 ×	10 ⁶	= 10000000 pF	= 10000 nF	=10 μF

Capacitance Tolerance

F = ±1%, G = ±2%, H = ±2.5%, I = ±3.5%, J = ±5%, K = ±10%, L = ±15%, M = ±20%, N=±40%

Rated Voltage

One digit and one letter (2A) or two digits (05) indicate rated voltage

Rated Voltage Codification

For DC Rated Voltage													
A		B		C		D		E		F		G	
1A	10	1B	12.5	1C	16	1D	20	1E	25	1F	30	1G	40
2A	100	2B	125	2C	160	2D	200	2E	250	2F	300	2G	400
3A	1000	3B	1250	3C	1600	3D	2000	3E	2500	3F	3000	3G	4000
H		I		J		K		L		M		N	
1H	50	1I	45	1J	63	1K	70	1L	80	1M	85	1N	90
2H	500	2I	450	2J	630	2K	700	2L	800	2M	850	2N	900
3H	5000	3I	4500	3J	6300	3K	7000	3L	8000	3M	8500	3N	9000
O		P		Q		R		S		U		V	
1O	110	1P	120	1Q	1U	1U	15	1S	17	1U	130	1V	60
2O	1100	2P	1200	2Q	2U	2U	150	2S	170	2U	1300	2V	600
3O	11000	3P	12000	3Q	3U	3U	1500	3S	1700	3U	13000	3V	6000
For AC Rated Voltage													
01	02	03	04	05	06	07	08	09	10	11	12	13	14
190 VAC	250 VAC	275 VAC	305 VAC	310 VAC	440 VAC	500 VAC	600 VAC	700 VAC	63 VAC	230 VAC	330 VAC	400 VAC	450 VAC

only better

06 Metallized Polyester Film Capacitors MPET – (Box Type) 10-27.5mm Pitch

*Packing Type details:

- 1: Bulk packing (original pitch)
- 2: Bulk packing (after forming & cutting)
- 3: Ammo packing (after forming & taping)
- 4: Bulk packing (after forming in original pitch without cut)
- 5: Bulk packing (after formed & without cut)
- 6: Ammo packing (Straight lead)
- 7: Bulk packing (Straight lead cut)
- 8: Reel packing (Straight lead)

Reference Data

Capacitance	0.001 μ F to 10 μ F
Capacitance tolerance	\pm 5% and \pm 10%
Rated DC Voltage	63Vdc to 1000Vdc
Permissible AC Voltage at 50/60 Hz	50Vac to 250Vac
Climatic testing class according to IEC 60068-1	40/105/56
Maximum application temperature	105°C
Rated temperature	85°C
Reference standards	IEC 60384-2
Dielectric	Polyester
Electrodes	Metallized
Construction	Mono
Encapsulation	Encased in flame retardant box filled with resin
Leads	Tinned wire
Marking on capacitor body	Type of capacitor, rated capacitance, rated tolerance, rated voltage and traceability code will be available on each and every capacitor. Example- D473K2J 9HMT023, or MPET D105K2J 902231234
Compatibility to RoHS	

Dimensions Description

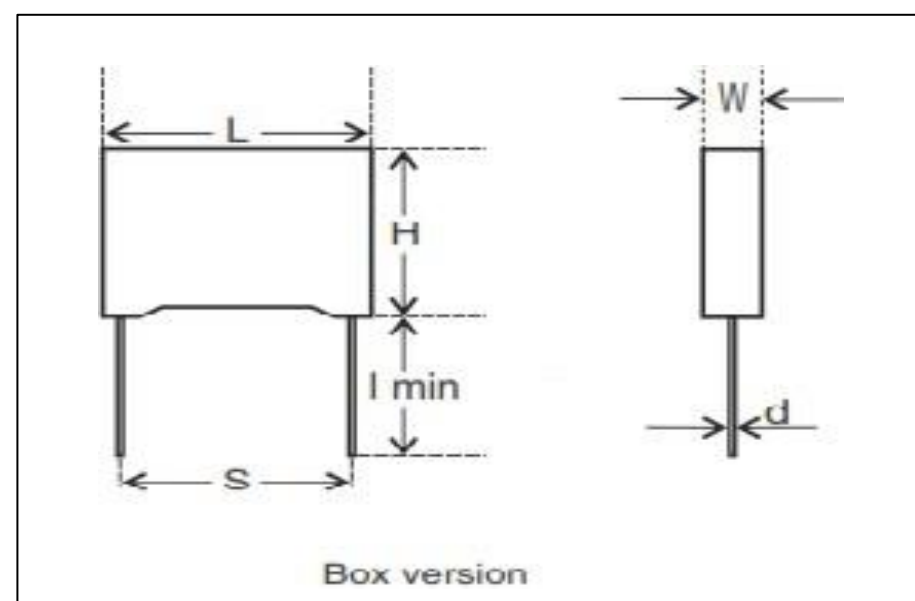

06 Metallized Polyester Film Capacitors MPET – (Box Type) 10-27.5mm Pitch

Rated voltage	Rated Capacitance (μF)	Dimensions (mm)					l	dV/dt (V/μs)	Item Code
		W ±(0.5)	H ±(0.5)	L ±(0.5)	d ±(0.05)	S ±(0.75)			
63 VDC	1.5	6	12	18	0.8	15	15 Min.	-	06 155 M 1J 1 A
100 VDC	0.01	5	11	13	0.6	10	15 Min.	28	06 103 K 2A 1 A
	0.056	4	9	13	0.6	10	15 Min.	28	06 563 +2A [^]
	0.082	4	9	13	0.6	10	15 Min.	28	06 823 +2A [^]
	0.1	4	9	13	0.6	10	15 Min.	28	06 104 +2A [^]
	0.15	5	11	13	0.6	10	15 Min.	28	06 154 +2A [^]
	0.22	4.5	9.5	13	0.6	10	15 Min.	28	06 224 +2A [^]
	0.33	5	11	19	0.8	15	15 Min.	20	06 334 +2A [^]
	0.47	5.5	11.5	19	0.8	15	15 Min.	20	06 474 +2A [^]
	0.68	6	12	19	0.8	15	15 Min.	20	06 684 +2A [^]
	1	7.5	13.5	19	0.8	15	15 Min.	20	06 105 +2A [^]
	1	6	12	18	0.8	15	15 Min.	20	06 105 K 2A 1 A
	1.5	6	12	19	0.8	15	15 Min.	8	06 155 +2A [^]
	2.0	8	14	13	0.6	10	15 Min.	28	06 205 K 2A 1 M
	2.2	6.5	16.5	27	0.8	22.5	15 Min.	8	06 225 +2A [^]
	2.2	8.5	14.5	18	0.8	15	6±0.4	20	06 225 K 2A 7 Z
	3.3	8.5	18	27	0.8	22.5	15 Min.	8	06 335 +2A [^]
	4.7	9.5	18.5	32	0.8	27.5	15 Min.	7	06 475 +2A [^]
4.7	11	19	18	0.8	15	15 Min.	20	06 475 K 2A 1 A	
4.7	8.5	17.0	26.5	0.8	22.5	15 Min.	20	06 475 J 2A 1 S	
6.8	11.5	20.5	32	0.8	27.5	15 Min.	7	06 685 +2A [^]	
160 VDC	1.0	6	15	26.5	0.8	22.5	15 Min.	10	06 105 K 2C 1 B
250 VDC	0.027	4	9	13	0.6	10	15 Min.	70	06 273 +2E [^]
	0.033	4	9	13	0.6	10	15 Min.	70	06 333 +2E [^]
	0.047	4	9	13	0.6	10	15 Min.	70	06 473 +2E [^]
	0.068	4.5	9.5	13	0.6	10	15 Min.	70	06 683 +2E [^]
	0.082	5	11	13	0.6	10	15 Min.	70	06 823 +2E [^]
	0.1	5	11	13	0.6	10	15 Min.	70	06 104 +2E [^]
	0.15	5	11	19	0.8	15	15 Min.	28	06 154 +2E [^]
	0.22	6	12	19	0.8	15	15 Min.	28	06 224 +2E [^]
	0.33	7	13	19	0.8	15	15 Min.	28	06 334 +2E [^]
	0.47	5.5	14.5	27	0.8	22.5	15 Min.	12	06 474 +2E [^]
	0.68	6.5	15.5	27	0.8	22.5	15 Min.	12	06 684 +2E [^]
	1	7.5	16.5	27	0.8	22.5	15 Min.	12	06 105 +2E [^]
	1	8.5	17	26.5	0.8	22.5	15 Min.	12	06 105 J 2E 1 A
	1	8.5	14	18.0	0.8	15	15 Min.	12	06 105 J 2E 1 B
	1.5	8.5	17.5	32	0.8	27.5	15 Min.	10	06 155 +2E [^]
2.2	10.5	19.5	32	0.8	27.5	15 Min.	10	06 224 +2E [^]	
15	18	28	31	0.8	27.5	4±0.5	10	06 156 K 2E 1 A	
400 VDC	0.01	4	9	13	0.6	10	15 Min.	110	06 103 +2G [^]
	0.01	5	11	13	0.6	10	15 Min.	110	06 103 K 2G 1 A
	0.015	4	9	13	0.6	10	15 Min.	110	06 153 +2G [^]
	0.022	4	9	13	0.6	10	15 Min.	110	06 223 +2G [^]
	0.033	4.5	9.5	13	0.6	10	15 Min.	110	06 333 +2G [^]
	0.047	4.5	10.5	19	0.8	15	15 Min.	44	06 473 +2G [^]
	0.068	5	11	13	0.8	15	15 Min.	44	06 683 +2G [^]
	0.1	5	11	13	0.6	10	15 Min.	44	06 104 K 2G 1 S
	0.1	5.5	12.5	19	0.8	15	15 Min.	44	06 104 +2G [^]
	0.15	5.5	12.5	19	0.8	15	15 Min.	44	06 154 +2G [^]
	0.22	6	15	27	0.8	22.5	15 Min.	20	06 224 +2G [^]
	0.33	6	15	27	0.8	22.5	15 Min.	20	06 334 +2G [^]
	0.47	7.5	16.5	27	0.8	22.5	15 Min.	20	06 474 +2G [^]
	1.5	11.0	20.0	26.5	0.8	22.5	15 Min.	20	06 155 J 2G 1 A
	0.56	7.5	16.5	32	0.8	27.5	15 Min.	16	06 564 +2G [^]
0.82	9	18	32	0.8	27.5	15 Min.	16	06 824 +2G [^]	
1	10	19	32	0.8	27.5	15 Min.	16	06 105 +2G [^]	
450 VDC	0.22	6.0	12.0	18	0.8	15	15 Min.	44	06 224 J 2I 1 A
630 VDC	0.01	5	11	13	0.6	10	15 Min.	70	06 103 +2J [^]
	0.015	5	11	13	0.6	10	15 Min.	70	06 153 +2J [^]
	0.022	5	11	13	0.6	10	15 Min.	70	06 223 +2J [^]
	0.033	6	12	19	0.8	15	15 Min.	70	06 333 +2J [^]

only better

06 Metallized Polyester Film Capacitors MPET – (Box Type) 10-27.5mm Pitch

0.047	7	13	19	0.8	15	15 Min.	70	06 473 +2J [^]
0.068	8	14	19	0.8	15	15 Min.	70	06 683 +2J [^]
0.082	5.5	14.5	27	0.8	22.5	15 Min.	28	06 823 +2J [^]
0.47	11.0	20.0	26.5	0.8	22.5	15 Min.	28	06 474 K 2J 1 B
0.1	6	15	27	0.8	22.5	15 Min.	28	06 104 +2J [^]
0.15	7.5	16.5	27	0.8	22.5	15 Min.	28	06 154 +2J [^]
0.22	9.5	18.5	27	0.8	22.5	15 Min.	28	06 224 +2J [^]
0.33	10	19	32	0.8	27.5	15 Min.	24	06 334 +2J [^]
0.47	12	21	32	0.8	27.5	15 Min.	24	06 474 +2J [^]

Specific Data

Description	Value			
	Frequency	C _R ≤ 0.1 μF	0.1 μF < C _R ≤ 1 μF	C _R > 1 μF
Maximum tangent of loss angle (Tan δ)	1 kHz	0.008	0.01	0.01
	10 kHz	0.015	0.02	-
	100 kHz	0.03	-	-
Voltage proof test between leads	1.6 times of the rated DC voltage for 2 second			
Insulation Resistance (R _{IS}) (or) time constant T = C _R × R _{IS} at 25° C, relative humidity ≤ 70%	Rated Voltage	C _R ≤ 0.33 μF	C _R > 0.33 μF	
	≤ 100 Vdc	≥ 3750 MΩ	≥ 1250 s	
	> 100 Vdc	≥ 7500 MΩ	≥ 2500 s	

Endurance Test

Loaded at 1.25 times of rated voltage at 85°C or 1.25 times of the category voltage at 105°C for 1000 hours.
Category voltage is 75% of the rated voltage.

After The Test

ΔC/C : ≤ 10% of initial value.

Tan δ : ≤ 0.005 at 100 kHz

Insulation resistance : ≥ 50% of the value mentioned in specific data.

Temperature Derating Graph

For temperature between 85°C and 100°C a decreasing factor of 1.25% per °C on the rated voltage V_R has to be applied.

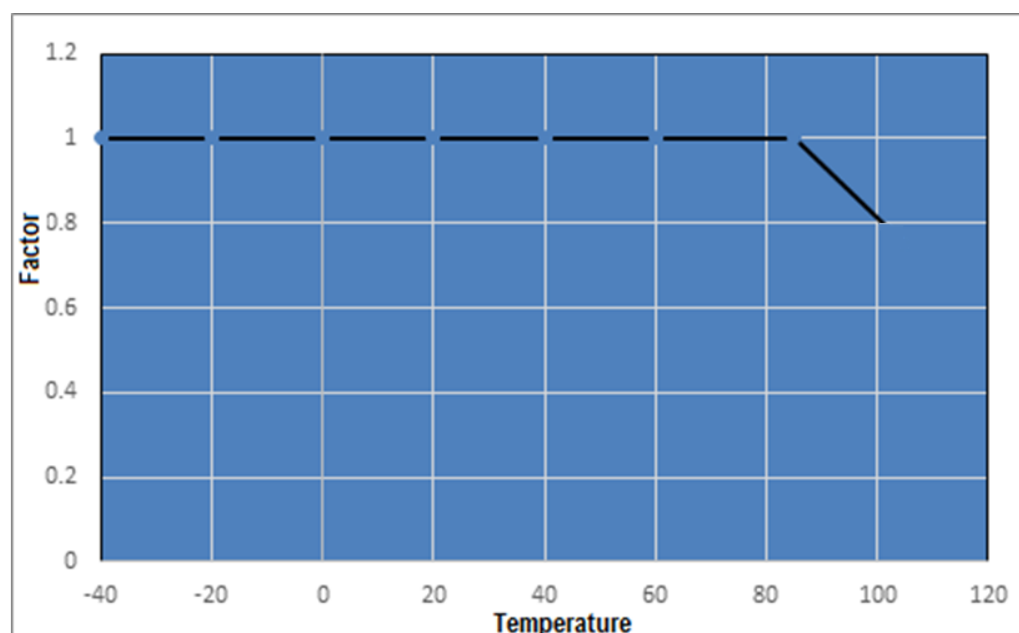

06 Metallized Polyester Film Capacitors

MPET – (Box Type) 10-27.5mm Pitch

Power Dissipation and Maximum Component Temperature Rise

After applying the A.C voltage to the capacitor with certain frequency, we can measure the hot spot temperature of the capacitor. From that we can calculate ΔT .

ΔT = hot spot temperature – ambient temperature

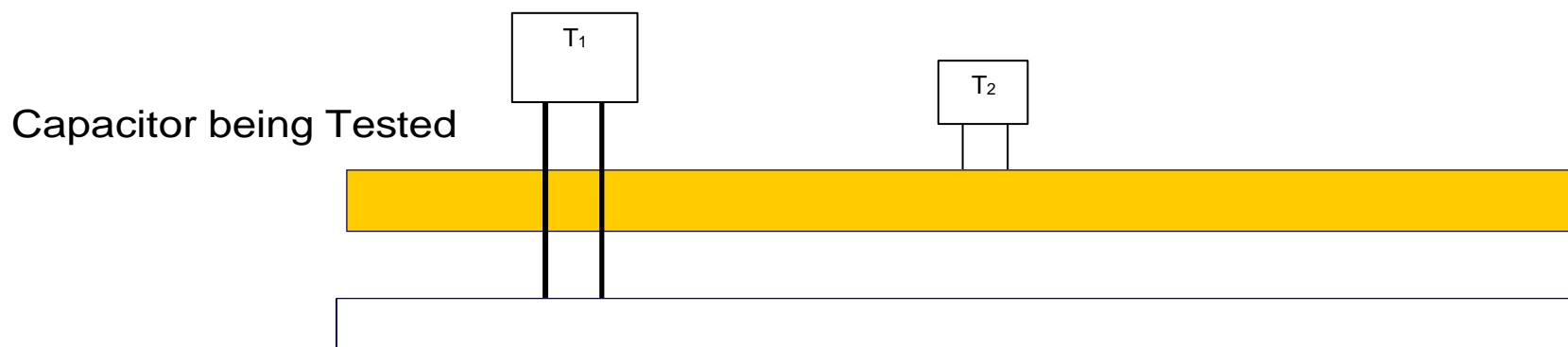

T₁ is the capacitor under test (Connected in the circuit)

T₂ is capacitor which has no connection

Distance between T₁ and T₂ should be about 50mm and 100mm from other components. To avoid radiation or convection, the capacitor should be tested in a wind-free box. The capacitor under test is separated by polystyrene.

$$\Delta T_{\max} = T_1 - T_2$$

at one frequency level the ΔT_{\max} reach 10°C. That is the frequency which we have to start frequency derating.

Storage Conditions

Avoid storing the capacitors in places where the environmental conditions differ from the following:

Storage time: ≤ 24 months from the date marked on the label glued to the package.

- Temperature: -40 to 80°C
- Humidity:

- Average per year: ≤70%
- For 30 full days randomly distributed throughout the year: ≤85%
- Dew: absent

After a longer period of storage or use, the tolerance can increase; but, according to standard specification, it may never exceed twice the value measured at the time of delivery.

Disclaimer

All our capacitors are designed, manufactured and tested to specifications. We strictly adhere to standards in procurement of materials, in the laid down manufacturing processes and consistently apply stringent process controls and testing parameters. This ensures that our capacitors always perform to the offered specifications.

Appropriateness of use in a specific circuit and fitness to a particular application however needs to be verified and its reliability through expected lifetime is required to be validated by the customer. Deki's responsibility is limited to ensuring that the capacitor performs as claimed in the specification/ data sheets provided by Deki. Deki specifically disclaims any implied warranties of fitness for any particular purpose. Liability, in any case is limited to the price paid for the capacitors.