

Film Capacitors

Series/Type: Metallized Polypropylene Film Capacitors
(MPP-Dip Type)

Series code: 04

Part Number Description

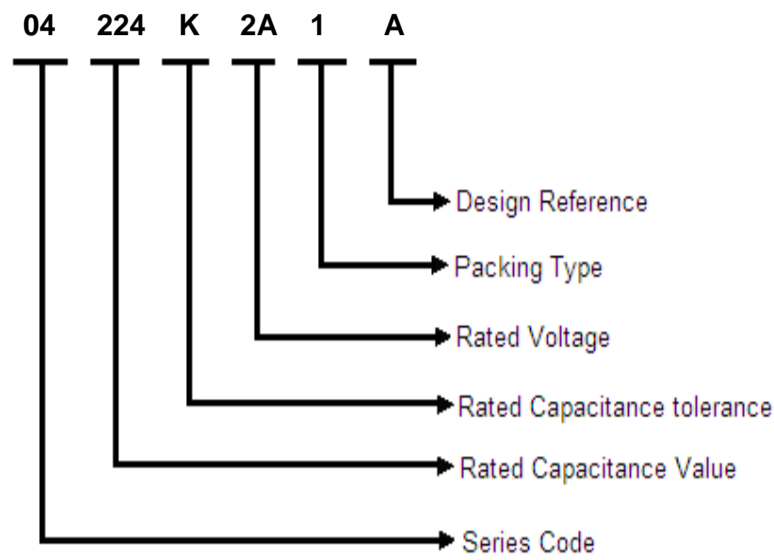

Rated Capacitance

Three-digit (224) indicate rated capacitance in Pico Farad (First two digits indicate value & third digit indicates number of zeroes to be suffixed to first two digits).

For example:

103	= 10 ×	10 ³	=	10000 pF	=	10 nF	=	0.01 μF
104	= 10 ×	10 ⁴	=	100000 pF	=	100 nF	=	0.1 μF
105	= 10 ×	10 ⁵	=	1000000 pF	=	1000 nF	=	1 μF
106	= 10 ×	10 ⁶	=	10000000 pF	=	10000 nF	=	10 μF

Capacitance Tolerance

F = ±1%, G = ±2%, H = ±2.5%, I = ±3.5%, J = ±5%, K = ±10%, L = ±15%, M = ±20%, N = ±40%

Rated Voltage

In 4th group of the part number, one numeric digit and one letter (Ex.-2A) indicate DC voltage rating while two numeric digits (Ex.03) indicate AC voltage rating.

Rated Voltage Codification

For DC Rated Voltage													
A		B		C		D		E		F		G	
1A	10	1B	12.5	1C	16	1D	20	1E	25	1F	30	1G	40
2A	100	2B	125	2C	160	2D	200	2E	250	2F	300	2G	400
3A	1000	3B	1250	3C	1600	3D	2000	3E	2500	3F	3000	3G	4000
H		I		J		K		L		M		N	
1H	50	1I	45	1J	63	1K	70	1L	80	1M	85	1N	90
2H	500	2I	450	2J	630	2K	700	2L	800	2M	850	2N	900
3H	5000	3I	4500	3J	6300	3K	7000	3L	8000	3M	8500	3N	9000
O		P		Q		R		S		T		U	
1O	110	1P	120	1Q	57.5	1R	15	1S	17	1T	70	1U	130
2O	1100	2P	1200	2Q	575	2R	150	2S	170	2T	700	2U	1300
3O	11000	3P	12000	3Q	5750	3R	1500	3S	1700	3T	70000	3U	13000

For AC Rated Voltage													
01	02	03	04	05	06	07	08	09	10	11	12	13	14
190 VAC	250 VAC	275 VAC	305 VAC	310 VAC	440 VAC	500 VAC	600 VAC	700 VAC	63 VAC	230 VAC	330 VAC	400 VAC	450 VAC

04 Metallized Polypropylene Film Capacitors

MPP - Dip Type

*Packing Type details:

- 1: Bulk packing (original pitch)
- 2: Bulk packing (after forming & cutting)
- 3: Ammo packing (after forming & taping)
- 4: Bulk packing (after forming in original pitch without cut)
- 5: Bulk packing (after formed & without cut)
- 6: Ammo packing (Straight lead)
- 7: Bulk packing (Straight lead cut)
- 8: Reel packing (Straight lead)

Reference Data

Capacitance	0.001 μ F to 6.8 μ F
Capacitance Tolerance	\pm 5% to \pm 10%
Rated Voltage	100 Vdc to 1000 Vdc
Permissible AC voltage at 50Hz/60Hz	63 Vac to 250 Vac
Climatic testing class according to IEC 60068-1	40/100/56
Maximum application temperature	100°C
Rated temperature	85°C
Reference standards	IEC 60384-16
Dielectric	Polypropylene
Electrodes	Metallized
Construction	Mono
Encapsulation	Coated with flame retardant epoxy powder
Leads	Tinned wire
Marking on capacitor body	Type of capacitor, rated capacitance, rated tolerance, rated voltage and traceability code will be available on each and every capacitor. Example- D473K2J 9HMP023, or MPP D105K2J 902231234
Compatibility to RoHS	

Dimensions Description

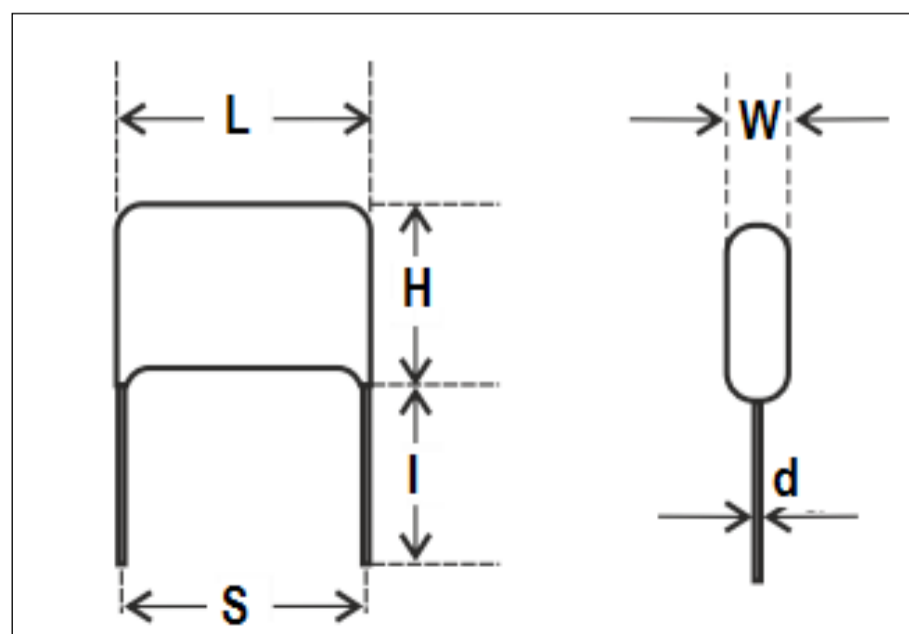

04 Metallized Polypropylene Film Capacitors

MPP - Dip Type



Rated Voltage	Rated Capacitance (μF)	Dimensions (mm)						dV/dt (V/μs)	Part Number
		L	H	W	S	d	l		
		(Max)	(Max)	(Max)		(±0.05)			
100Vdc/63Vac	0.1	12.5	16	6	10±0.5	0.6	5±1.0	30	04 104 J 2A 2 A
	0.15	12.5	12	8	10±0.75	0.6	17 Min.	30	04 154 J 2A 1 A
	0.15	12.5	16	8	10±0.5	0.6	5±1.0	30	04 154 J 2A 2 A
	0.47	17.5	15	9	15±0.75	0.8	17 Min.	20	04 474 J 2A 1 A
	6.8	31	26	15.5	27.5±1.0	0.8	17 Min.	7	04 685 K 2A 1 A
	6.8	31	26	15.5	27.5±1.0	0.8	17 Min.	7	04 685 K 2A 1 U
	1.0	12.5	19	14	10±0.5	0.6	17 Min.	-	04 105 K 2A 1 A
250Vdc/160Vac	0.047	12.5	10	6	10±0.75	0.6	17 Min.	70	04 473 K 2E 1 A
	0.047	12.5	14	6	10±0.5	0.6	4.5±1.0	70	04 473 K 2E 2 A
	0.1	12.5	12	6	10±0.75	0.6	17 Min.	70	04 104 J 2E 1 A
	0.1	12.5	12	6	10±0.75	0.6	17 Min.	70	04 104 K 2E 1 A
	0.1	12.5	16	6	10±0.5	0.6	5±1.0	70	04 104 I 2E 2 A
	0.15	17.5	16	7	15±0.5	0.8	5±1.0	60	04 154 J 2E 2 A
	0.18	17.5	19	8	7.5±0.5	0.8	5±1.0	60	04 184 J 2E 2 A
	0.22	17.5	12	7	15±0.75	0.8	17 Min.	60	04 224 K 2E 1 A
	0.22	17.5	17	7	22.5±0.5	0.8	3.75±1.0	60	04 224 K 2E 2 B
	0.22	17.5	17	7	22.5±0.5	0.8	14 Min.	60	04 224 K 2E 5 A
	0.22	17.5	17	7	15±0.5	0.8	14 Min.	60	04 224 K 2E 5 B
	0.27	26	12	7	22.5±0.5	0.8	5±1.0	30	04 274 J 2E 7 A
	0.27	26	17	7	20±0.5	0.8	5±1.0	30	04 274 J 2E 2 A
	0.3	26	17	7	22.5±1.0	0.8	17 Min.	30	04 304 J 2E 1 A
	0.3	26	17	7	22.5±1.0	0.8	17 Min.	30	04 304 K 2E 1 A
	0.33	26	13	8	22.5±1.0	0.8	17 Min.	30	04 334 J 2E 1 A
	0.35	26	19	8	15±0.5	0.8	5±1.0	30	04 354 I 2E 2 A
	0.39	26	15	8	22.5±1.0	0.8	17 Min.	30	04 394 J 2E 1 A
	0.4	26	19	8	15±0.5	0.8	5±1.0	30	04 404 I 2E 2 A
	0.43	26	14	7	22.5±1.0	0.8	17 Min.	30	04 434 J 2E 1 A
	0.43	26	19	7	15±0.5	0.8	5±1.0	30	04 434 J 2E 2 A
	0.47	26	13	8	22.5±1.0	0.8	17 Min.	30	04 474 J 2E 1 A
	0.47	26	17	10	15±0.5	0.8	5±1.0	30	04 474 I 2E 2 A
	0.47	26	17	10	20±0.5	0.8	5±1.0	30	04 474 J 2E 2 A
	0.53	26	19	7	17.5±0.5	0.6	5±1.0	30	04 534 I 2E 2 A
	0.68	26	17	9.5	22.5±1.0	0.8	17 Min.	30	04 684 K 2E 1 A
	0.68	26	18	10	22.5±1.0	0.8	17 Min.	30	04 684 J 2E 1 B
	0.68	26	18	10	22.5±1.0	0.8	17 Min.	30	04 684 K 2E 1 B
	0.7	26	25	11	22.5±0.5	0.8	14 Min.	30	04 704 J 2E 4 L
	0.8	26	19	11	22.5±1.0	0.8	17 Min.	30	04 804 J 2E 1 A
	1	26	15	8	10±0.75	0.8	17 Min.	30	04 105 K 2E 1 C
	1	26	22	10	20±0.5	0.8	5±1.0	30	04 105 I 2E 2 A
	1	26	22	10	10±0.5	0.8	5±1.0	30	04 105 I 2E 2 B
2.2	31	18	10	27.5±1.0	0.8	17 Min.	20	04 225 K 2E 1 W	
2.2	31	21	12	27.5±1.0	0.8	17 Min.	20	04 225 K 2E 1 A	
2.2	25.5	20.5	10.5	22.5	0.8	17 Min.	20	04 225 J 2E 1 Z	
400Vdc/200Vac	0.01	12.5	10.5	5.5	10±0.75	0.6	17 Min.	80	04 103 J 2G 1 A
	0.015	12.5	11	6	10±0.75	0.6	17 Min.	80	04 153 J 2G 1 A
	0.015	12.5	15	6	10±0.5	0.6	4.5±1.0	80	04 153 J 2G 2 A
	0.022	12.5	11	6	10±0.75	0.6	17 Min.	80	04 223 K 2G 1 A
	0.022	12.5	12	6	10±0.75	0.6	17 Min.	80	04 223 J 2G 1 A
	0.022	12.5	13	6.5	10±0.75	0.6	17 Min.	80	04 223 J 2G 1 B
	0.022	12.5	15	6	10±0.5	0.6	5±1.0	80	04 223 J 2G 2 A
	0.047	12.5	13.5	8	10±0.75	0.6	17 Min.	80	04 473 J 2G 1 A
	0.047	12.5	13.5	8	10±0.75	0.6	17 Min.	80	04 473 K 2G 1 A
	0.047	12.5	17	6	10±0.5	0.6	5±1.0	80	04 473 K 2G 2 A
	0.047	12.5	18.5	8	10±0.5	0.6	5±1.0	80	04 473 J 2G 2 A
0.1	17.5	12	7	15±0.75	0.8	17 Min.	70	04 104 J 2G 1 A	

only better

04 Metallized Polypropylene Film Capacitors

MPP - Dip Type



	0.1	17.5	12	7	15±0.75	0.8	17 Min.	70	04 104 K 2G 1 A
	0.1	17.5	17	7	15±0.5	0.8	5±1.0	70	04 104 I 2G 2 A
	0.1	17.5	17	7	15±0.5	0.8	5±1.0	70	04 104 K 2G 2 A
	0.15	17.5	13	8	15±0.75	0.8	17 Min.	70	04 154 J 2G 1 A
	0.15	17.5	13	8	15±0.75	0.8	17 Min.	70	04 154 K 2G 1 A
	0.15	17.5	17	8	15±0.5	0.8	5±1.0	70	04 154 J 2G 2 A
	0.15	17.5	17	8	15±0.5	0.8	5±1.0	70	04 154 K 2G 2 A
	0.16	17.5	18.5	8	15±0.5	0.8	14 Min.	70	04 164 J 2G 4 L
	0.18	17.5	15	8	15±0.75	0.8	17 Min.	70	04 184 J 2G 1 A
	0.18	17.5	15	8	15±0.75	0.8	17 Min.	70	04 184 K 2G 1 A
	0.18	17.5	20	8	7.5±0.5	0.8	14 Min.	70	04 184 J 2G 5 A
	0.22	17.5	16	8	15±0.75	0.8	17 Min.	70	04 224 J 2G 1 A
	0.22	17.5	16	8	15±0.75	0.8	17 Min.	70	04 224 K 2G 1 A
	0.22	17.5	21	8	15±0.5	0.8	5±1.0	70	04 224 J 2G 2 A
	0.22	17.5	21	8	15±0.5	0.8	5±1.0	70	04 224 K 2G 2 A
	0.22	17.5	22	11	15±0.5	0.8	5±1.0	70	04 224 J 2G 2 B
	0.22	26	13	7	22.5±1.0	0.8	17 Min.	35	04 224 J 2G 1 B
	0.22	26	13	7	22.5±1.0	0.8	17 Min.	35	04 224 K 2G 1 B
	0.25	26	15	7	22.5±1.0	0.8	17 Min.	35	04 254 J 2G 1 A
	0.27	26	19	7	20±0.5	0.8	5±1.0	35	04 274 J 2G 2 A
	0.3	26	18	8	22.5±1.0	0.8	17 Min.	35	04 304 J 2G 1 A
	0.3	26	22	10	22.5±0.5	0.8	14 Min.	35	04 304 J 2G 4 L
	0.33	17.5	17.5	10	15±0.75	0.8	17 Min.	70	04 334 K 2G 1 B
	0.33	17.5	21.5	10	15±0.5	0.8	14 Min.	70	04 334 J 2G 4 G
	0.33	26	15	8	22.5±1.0	0.8	17 Min.	35	04 334 J 2G 1 A
	0.33	26	15	8	22.5±1.0	0.8	17 Min.	35	04 334 K 2G 1 A
	0.33	26	20	8	22.5±0.5	0.8	14 Min.	35	04 334 J 2G 4 L
	0.39	26	15	9	22.5±1.0	0.8	17 Min.	35	04 394 J 2G 1 A
	0.39	26	20	9	20±0.5	0.8	5±1.0	35	04 394 J 2G 2 A
	0.47	17.5	15	9	15±0.75	0.8	17 Min.	70	04 474 K 2G 1 Z
	0.47	17.5	18	13	15±0.75	0.8	17 Min.	70	04 474 K 2G 1 B
	0.47	26	21.5	9	20±0.5	0.8	5±1.0	35	04 474 J 2G 2 A
	1	22	14.5	7	20±1.0	0.8	17 Min.	35	04 105 K 2G 1 B
	1	22	14.5	7	20±1.0	0.8	17 Min.	35	04 105 K 2G 1 Z
	1	31	18.5	7.5	27.5±1.0	0.8	17 Min.	29	04 105 K 2G 1 O
	0.047	12.5	11	6	10±0.75	0.5	17 Min.	80	04 473 K 2I 1 A
	0.047	12.5	11	6	10±0.5	0.5	5±1.0	80	04 473 K 2I 7 A
500Vdc/220Vac	0.056	17.5	13	7	15±0.5	0.6	5±1.0	90	04 563 J 2H 7 B
630Vdc/250Vac	0.0047	13.0	11	6	10±0.75	0.6	17 Min.	100	04 472 J 2J 1 A
	0.0068	12.5	14	6	7.5±0.5	0.6	14 Min.	100	04 682 J 2J 5 S
	0.01	12.5	10	5	10±0.75	0.6	17 Min.	100	04 103 J 2J 1 A
	0.01	12.5	10	5	10±0.75	0.6	17 Min.	100	04 103 K 2J 1 A
	0.01	12.5	14	5	7.5±0.5	0.6	17 Min.	100	04 103 J 2J 8 B
	0.01	12.5	12.5	7	10±0.5	0.6	17Min.	100	04 103 J 2J 1 C
	0.012	12.5	10	5.5	10±0.75	0.6	17 Min.	100	04 123 J 2J 1 A
	0.015	12.5	11	6	10±0.75	0.6	17 Min.	100	04 153 J 2J 1 A
	0.022	12.5	12	7	10±0.75	0.6	17 Min.	100	04 223 J 2J 1 A
	0.022	12.5	12	7	10±0.75	0.6	17 Min.	100	04 223 J 2J 1 U
	0.022	12.5	12	7	10±0.5	0.6	5±1.0	100	04 223 J 2J 7 A
	0.022	12.5	12	7	10±0.75	0.6	17 Min.	100	04 223 K 2J 1 A
	0.022	12.5	12	7	10±0.75	0.6	17 Min.	100	04 223 K 2J 1 V
	0.022	12.5	12	7	10±0.5	0.6	5±1.0	100	04 223 K 2J 7 A
	0.022	12.5	17.5	6	10±0.5	0.6	14 Min.	100	04 223 J 2J 4 L
	0.027	12.5	12	6	10±0.75	0.6	17 Min.	100	04 273 K 2J 1 A
	0.027	12.5	12.5	6.5	10±0.75	0.6	17 Min.	100	04 273 J 2J 1 C
	0.027	17.5	13	8	15±0.75	0.8	17 Min.	90	04 273 K 2J 1 B
	0.033	12.5	11.5	6.5	10±0.75	0.6	17 Min.	100	04 333 K 2J 1 B
	0.033	17.5	12	6.5	15±0.75	0.8	17 Min.	90	04 333 J 2J 1 A
	0.033	17.5	12	6.5	15±0.75	0.8	17 Min.	90	04 333 K 2J 1 A

only better

© Deki Electronics Ltd

B-19 & 20. Sector-58. Noida-201301. India • +91-120 2585458/57 • www.dekielectronics.com

04 Metallized Polypropylene Film Capacitors

MPP - Dip Type



	0.039	17.5	13	7.5	15±0.75	0.8	17 Min.	90	04 393 J 2J 1 A
	0.039	21	24	7.5	7.5±0.5	0.8	14 Min.	90	04 393 J 2J 4 L
	0.047	17.5	13	6.5	15±0.75	0.8	17 Min.	90	04 473 J 2J 1 F
	0.047	17.5	13	6.5	15±0.5	0.8	5±1.0	90	04 473 J 2J 7 F
	0.047	17.5	13	7	15±0.75	0.8	17 Min.	90	04 473 J 2J 1 E
	0.047	17.5	13	7	15±0.75	0.8	17 Min.	90	04 473 K 2J 1 E
	0.047	17.5	14	7.5	15±0.75	0.8	17 Min.	90	04 473 J 2J 1 A
	0.047	17.5	14	7.5	15±0.5	0.8	5±1.0	90	04 473 K 2J 7 A
	0.047	17.5	18	7.5	15±0.5	0.8	5±1.0	90	04 473 K 2J 2 A
	0.047	17.5	18.5	9	15±0.5	0.8	14 Min.	90	04 473 J 2J 4 L
	0.056	17.5	13.5	8	15±0.75	0.8	17 Min.	90	04 563 J 2J 1 A
	0.056	17.5	13.5	8	15±0.75	0.8	17 Min.	90	04 563 K 2J 1 A
	0.056	17.5	18.5	9	15±0.5	0.8	14 Min.	90	04 563 J 2J 4 L
	0.068	17.5	14	8	15±0.75	0.8	17 Min.	90	04 683 K 2J 1 A
	0.082	17.5	14	8	15±0.75	0.8	17 Min.	90	04 823 K 2J 1 A
	0.1	12.5	12.5	6.5	10±0.75	0.6	17 Min.	100	04 104 K 2J 1 B
	0.1	12.5	12.5	6.5	10±0.5	0.6	5±1.0	100	04 104 K 2J 7 B
	0.1	12.5	12.5	6.5	10±0.5	0.6	4±1.0	100	04 104 K 2J 7 C
	0.1	17.5	15	9	15±0.75	0.8	17 Min.	90	04 104 J 2J 1 A
	0.1	17.5	15	9	15±0.75	0.8	17 Min.	90	04 104 K 2J 1 A
	0.15	17.5	16	9.5	15±0.75	0.8	17 Min.	90	04 154 K 2J 1 B
	0.15	26	19.5	9	22.5±0.5	0.8	14 Min.	45	04 154 J 2J 4 L
	0.18	17.5	16.5	11	15±0.75	0.8	17 Min.	90	04 184 K 2J 1 B
	0.22	26	16.5	8.5	22.5±1.0	0.8	17 Min.	45	04 224 K 2J 1 A
	0.22	26	21	10	15±0.5	0.8	14 Min.	45	04 224 J 2J 5 A
	0.47	26	22	13	22.5±1.0	0.8	17 Min.	45	04 474 J 2J 1 B
	0.47	26	22	13	22.5±0.3	0.8	17 Min.	45	04 474 K 2J 1 B
	0.47	26	22	13	22.5±1.0	0.8	17 Min.	45	04 474 K 2J 1 V
	0.47	26	22	13	22.5±0.3	0.8	5±1.0	45	04 474 K 2J 7 B
	0.47	26	25.5	13.5	22.5±1.0	0.8	17 Min.	45	04 474 K 2J 1 D
	0.47	26	26	13	17.5±0.5	0.8	14 Min.	45	04 474 J 2J 5 A
	0.68	26	23.5	15	22.5±1.0	0.8	17 Min.	45	04 684 K 2J 1 A
	1.0	26	18	8.5	22.5±1.0	0.8	17 Min.	30	04 105 J 2J 1 A
	1.3	31	27.5	17.5	27.5±1.0	0.8	17 Min.	30	04 135 J 2J 1 B
	2.0	26	22	12.5	22.5±1.0	0.8	17 Min.	30	04 205 K 2J 1 A
	2.2	31	30	18	27.5±1.0	0.8	17 Min.	30	04 225 K 2J 1 A
1000Vdc	0.1	26	17.5	9	22.5±1.0	0.8	17 Min.	30	04 104 K 3A 1 A
	0.1	17.5	15.0	8.5	15±0.75	0.8	17 Min.	90	04 104 K 3A 1 B
	0.22	26	17	10	22.5±1.0	0.8	17 Min.	30	04 224 K 3A 1 A
	0.22	26	22	14	22.5±1.0	0.8	17 Min.	30	04 224 K 3A 1 U
	0.33	26	19	12	22.5±1.0	0.8	17 Min.	30	04 334 K 3A 1 A
	0.47	26	21	14	22.5±1.0	0.8	17 Min.	30	04 474 K 3A 1 A
	0.56	31	21	12	27.5±1.0	0.8	17 Min.	20	04 564 K 3A 1 A
	0.68	31	23	13	27.5±1.0	0.8	17 Min.	20	04 684 K 3A 1 A
	0.82	31	23	14	27.5±1.0	0.8	17 Min.	20	04 824 K 3A 1 B
	1	31	24.5	15.5	27.5±1.0	0.8	17 Min.	20	04 105 K 3A 1 B

only better

© Deki Electronics Ltd

B-19 & 20. Sector-58. Noida-201301. India • +91-120 2585458/57 • www.dekielectronics.com

Specific Data

Description	Value			
	Frequency	$C_R \leq 0.1 \mu F$	$0.1 \mu F < C_R \leq 1 \mu F$	$C_R > 1 \mu F$
Maximum tangent of loss angle (Tan δ)	1 kHz	0.0008	0.0008	0.001
	10 kHz	0.0015	0.0025	-
	100 kHz	0.0050	-	-
Voltage proof test between leads	1.6 times of the rated DC voltage for 2 second			
Insulation Resistance (R_{IS}) (or) time constant $T = C_R \times R_{IS}$ at 25° C, relative humidity $\leq 70\%$	$C_R \leq 0.1 \mu F$ $\geq 100000 M\Omega$		$C_R > 0.33 \mu F$ $\geq 30000 s$	

Temperature Derating Graph

For temperature between 85°C and 100°C a derating factor of 1.25% per °C on the rated voltage V_R has to be applied.

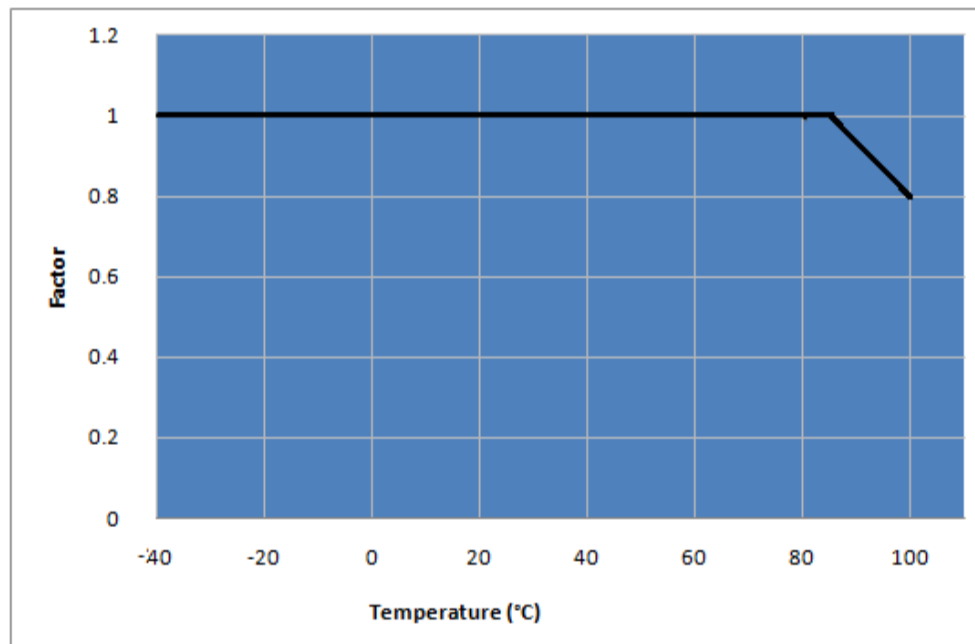

Power Dissipation and Maximum Component Temperature Rise

After applying the A.C voltage to the capacitor with certain frequency, we can measure the hot spot temperature of the capacitor. From that we can calculate ΔT .

$$\Delta T = \text{hot spot temperature} - \text{ambient temperature}$$

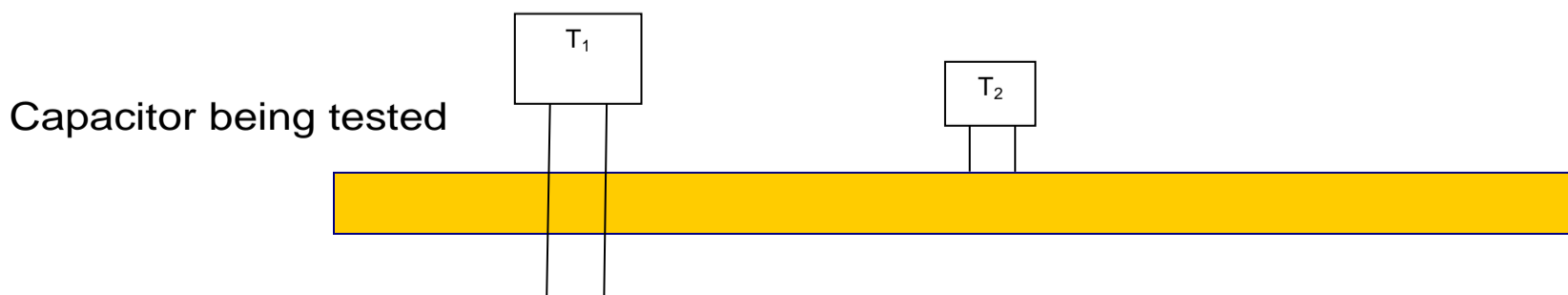

04 Metallized Polypropylene Film Capacitors

MPP - Dip Type



T1 is the capacitor under test (Connected in the circuit)
T2 is capacitor which has no connection

Distance between T1 and T2 should be about 50mm and 100mm from other components. To avoid radiation or convection, the capacitor should be tested in a wind-free box. The capacitor under test is separated by polystyrene.

$$\Delta T_{\max} = T1 - T2$$

At one frequency level the ΔT_{\max} reach 10°C . That is the frequency which we have to start frequency derating.

Storage Conditions

Avoid storing the capacitors in places where the environmental conditions differ from the following:

Storage time: ≤ 24 months from the date marked on the label glued to the package.

- Temperature: -40 to 80°C
- Humidity:

- Average per year: $\leq 70\%$
- For 30 full days randomly distributed throughout the year: $\leq 85\%$
- Dew: absent

After a longer period of storage or use, the tolerance can increase; but, according to standard specification, it may never exceed twice the value measured at the time of delivery.

Disclaimer

All our capacitors are designed, manufactured and tested to specifications. We strictly adhere to standards in procurement of materials, in the laid down manufacturing processes and consistently apply stringent process controls and testing parameters. This ensures that our capacitors always perform to the offered specifications.

Appropriateness of use in a specific circuit and fitness to a particular application however needs to be verified and its reliability through expected lifetime is required to be validated by the customer. Deki's responsibility is limited to ensuring that the capacitor performs as claimed in the specification/ data sheets provided by Deki. Deki specifically disclaims any implied warranties of fitness for any particular purpose. Liability, in any case is limited to the price paid for the capacitors.